

# **Freescale ( Motorola )**

## **8/16/32Bits MCU Introduction**

**Do Select Best MCU for Your Application!**

**Tsinghua Freescale MCU/DSP Application Center**

# CUSTOMER SPECIFIC INTEGRATED CIRCUIT

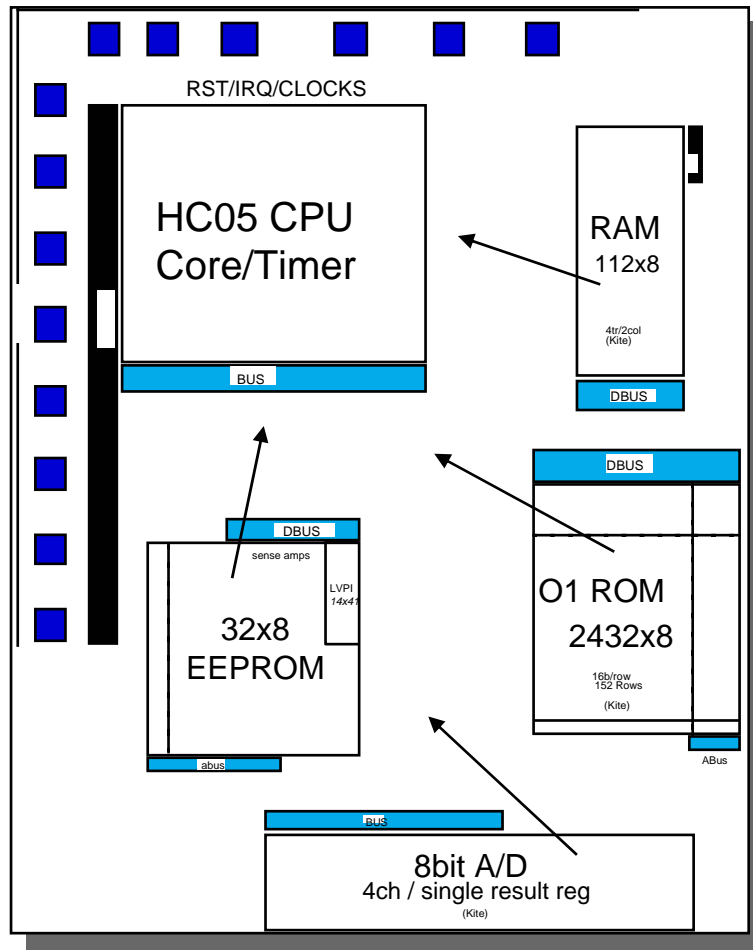

## Develop New MCU

- based on **PARTNERSHIP** with **Key Customer** to define feature set for customer application
- **Motorola does design** and is responsible for product introduction & qualification
- **CSIC** features a **Modular Design Methodology** to decrease Product Introduction Cycle
- Customer benefits from **Hand-packed Design** bringing **Cost Benefit** to High Vol. Application
- Motorola (normally) adds the device to **Standard Product Catalogue**

# Total MCU Market (to 200 亿\$)

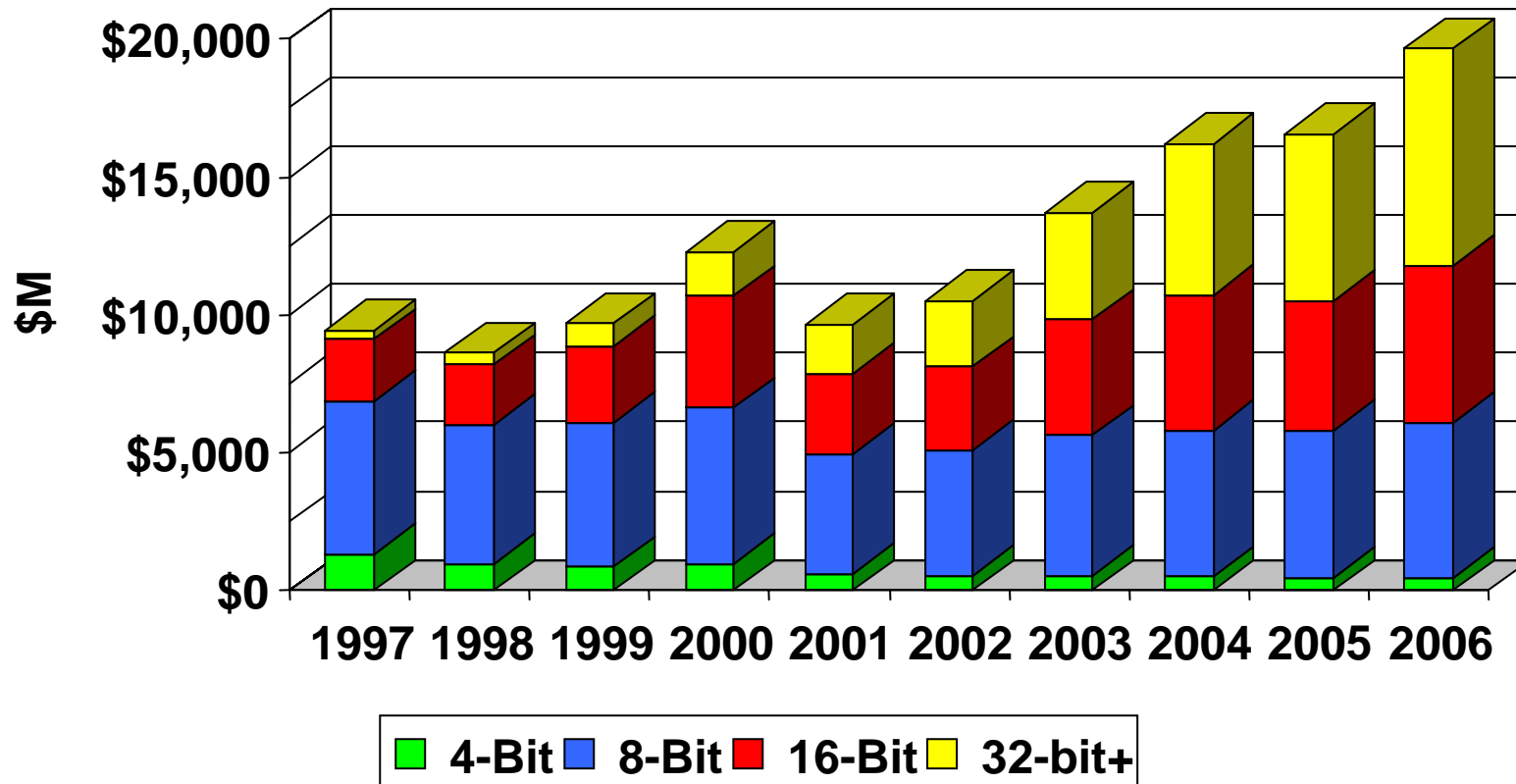

Resources from SEMICO Research Cooperation 2003

# Total MCU Market (pieces)

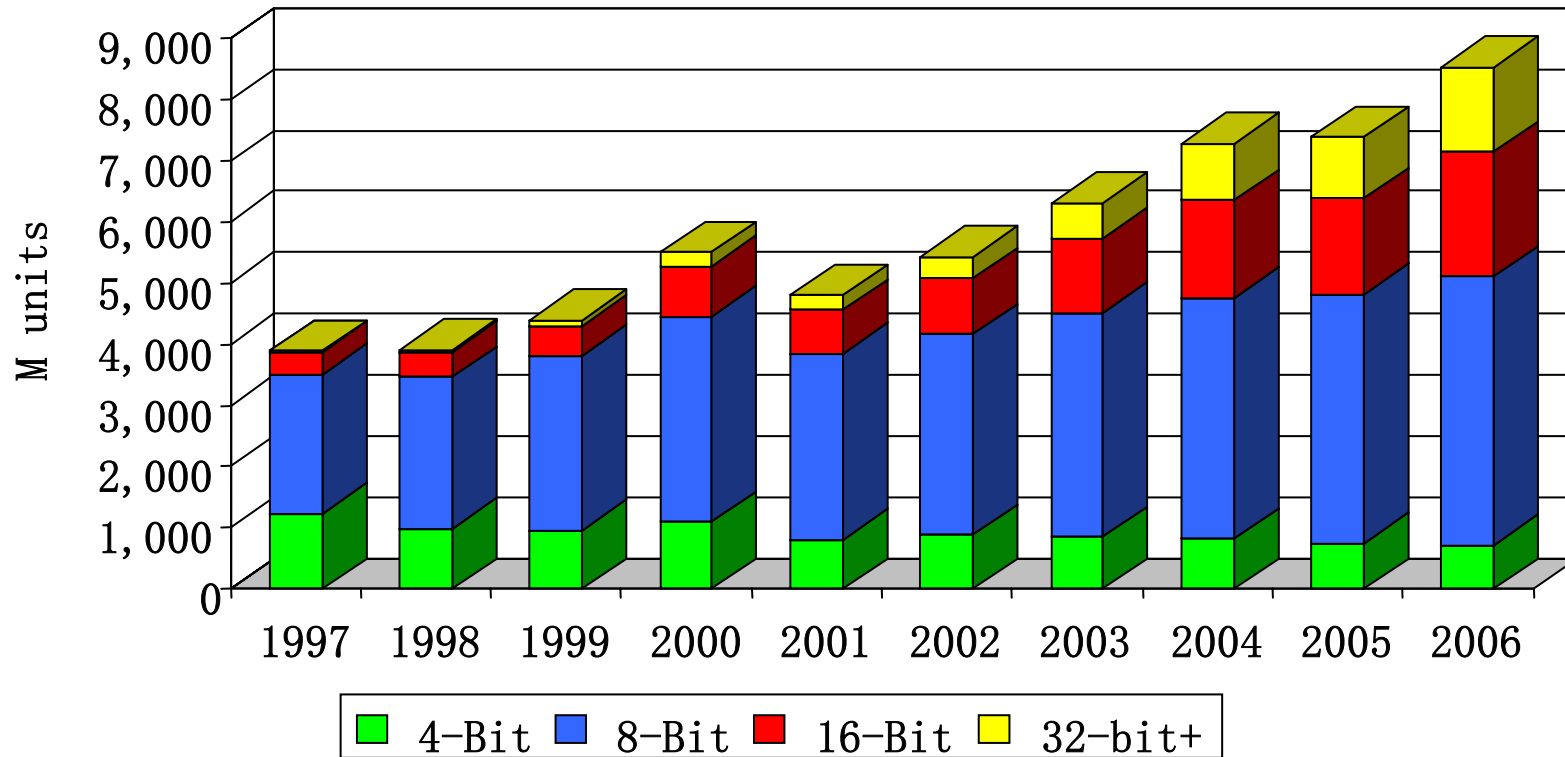

# 8-Bit Flash MCU

## High Growth In Units

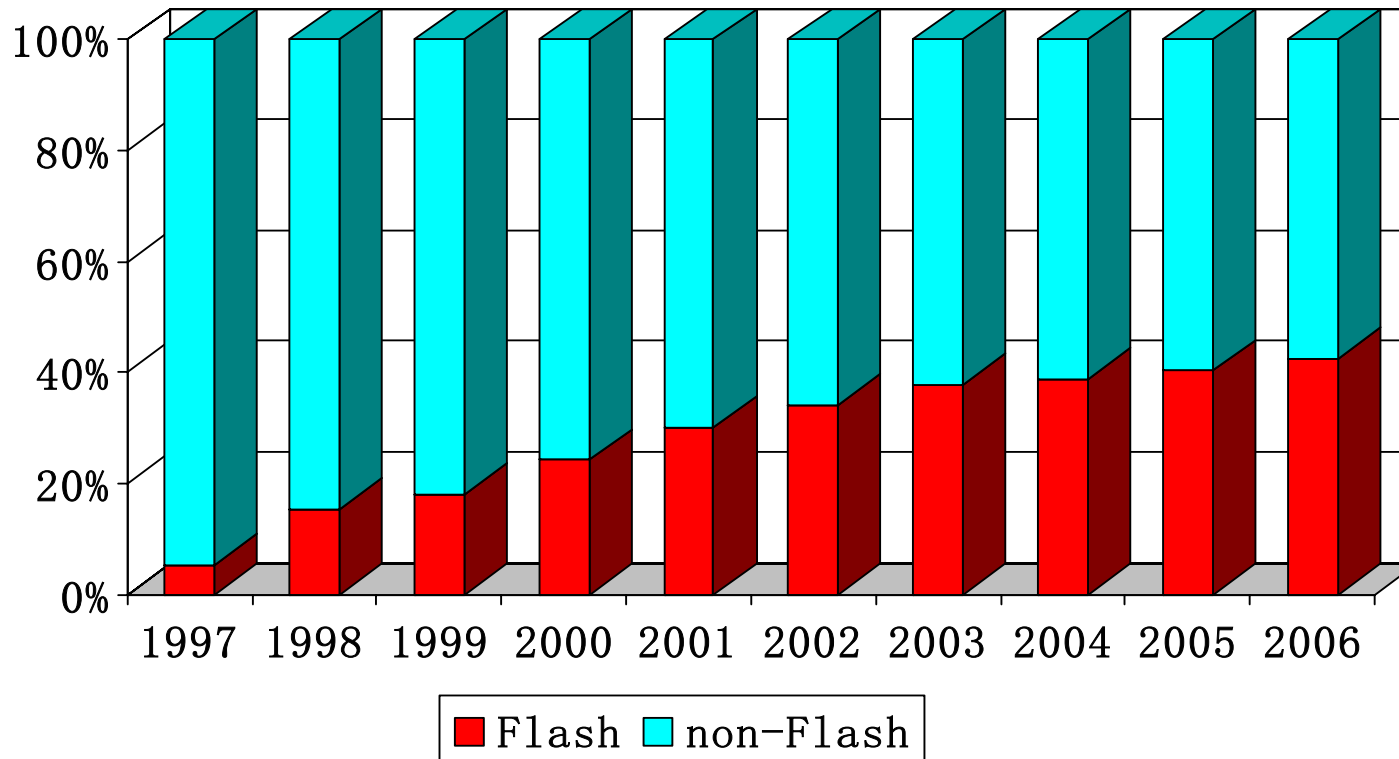

# Where Do 8-Bit MCUs Go?

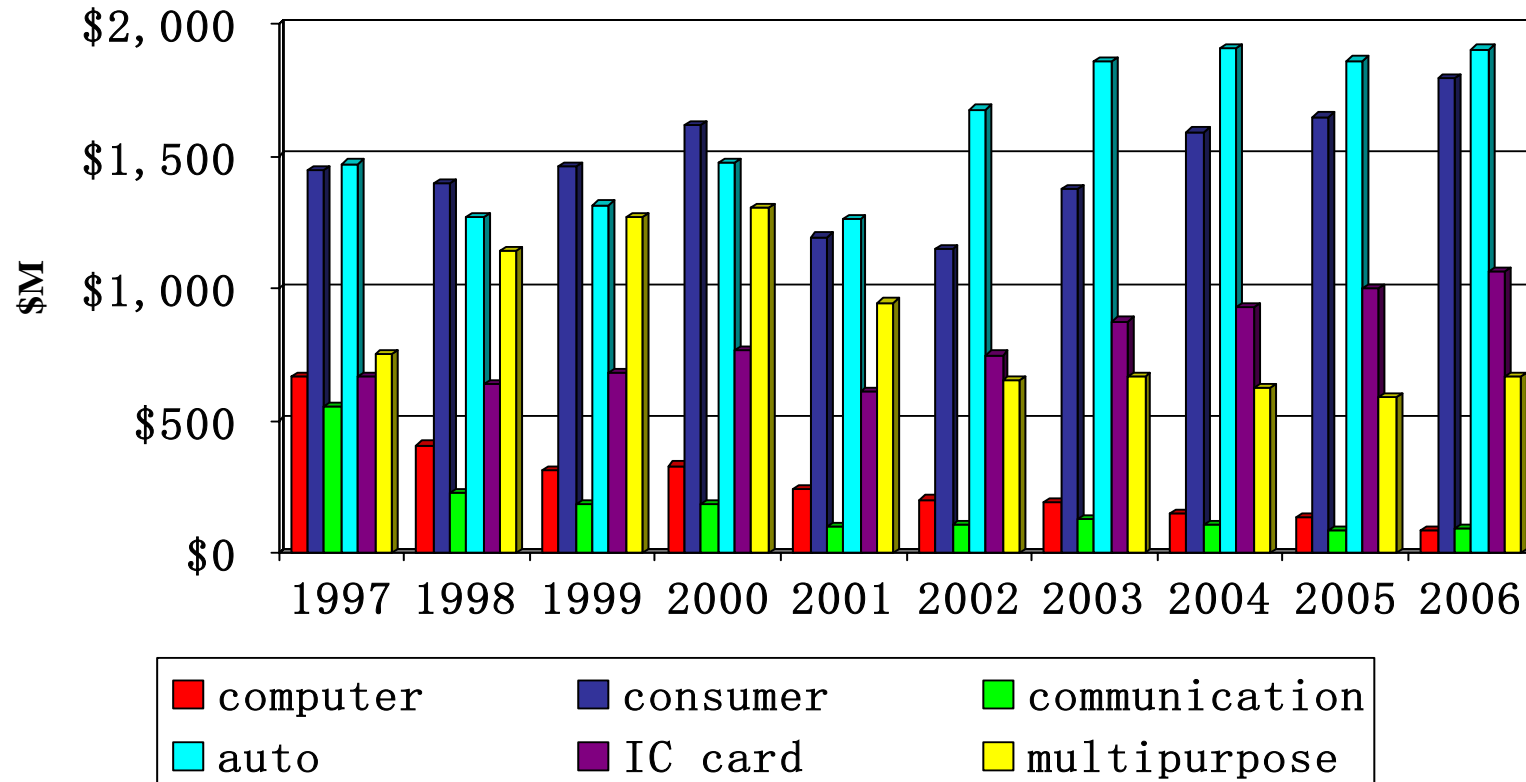

# 8-Bit MCU Market 2001 Market Share (\$)

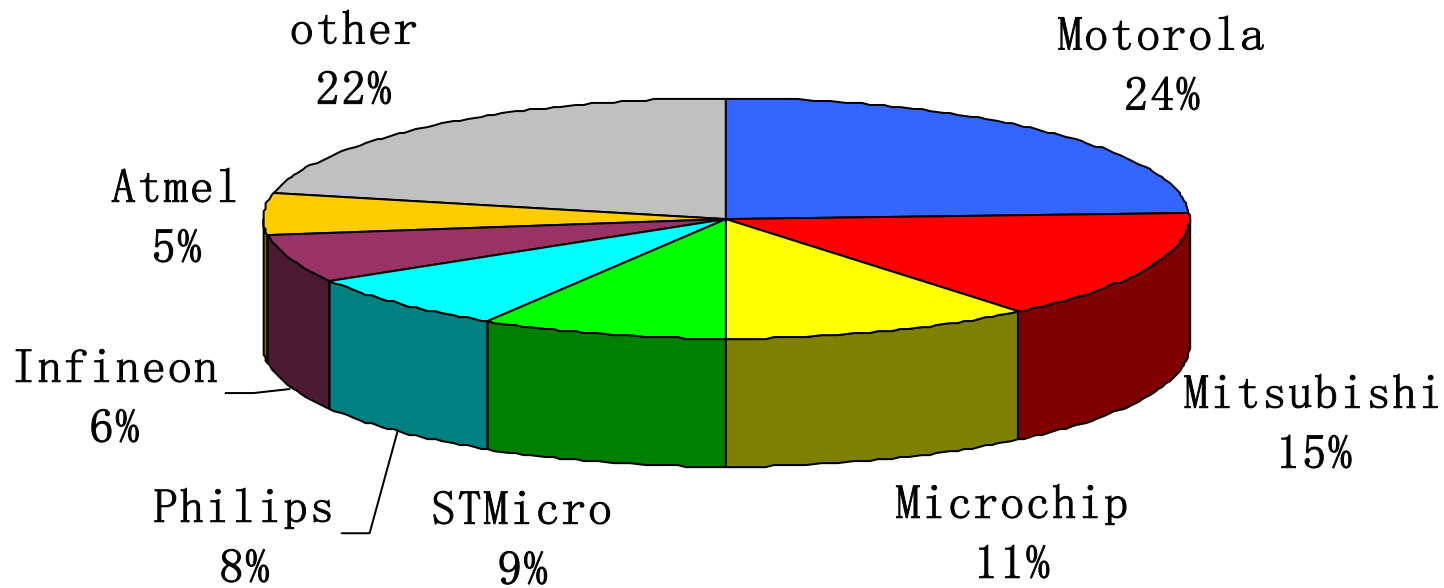

# History of Motorola 8bits Family

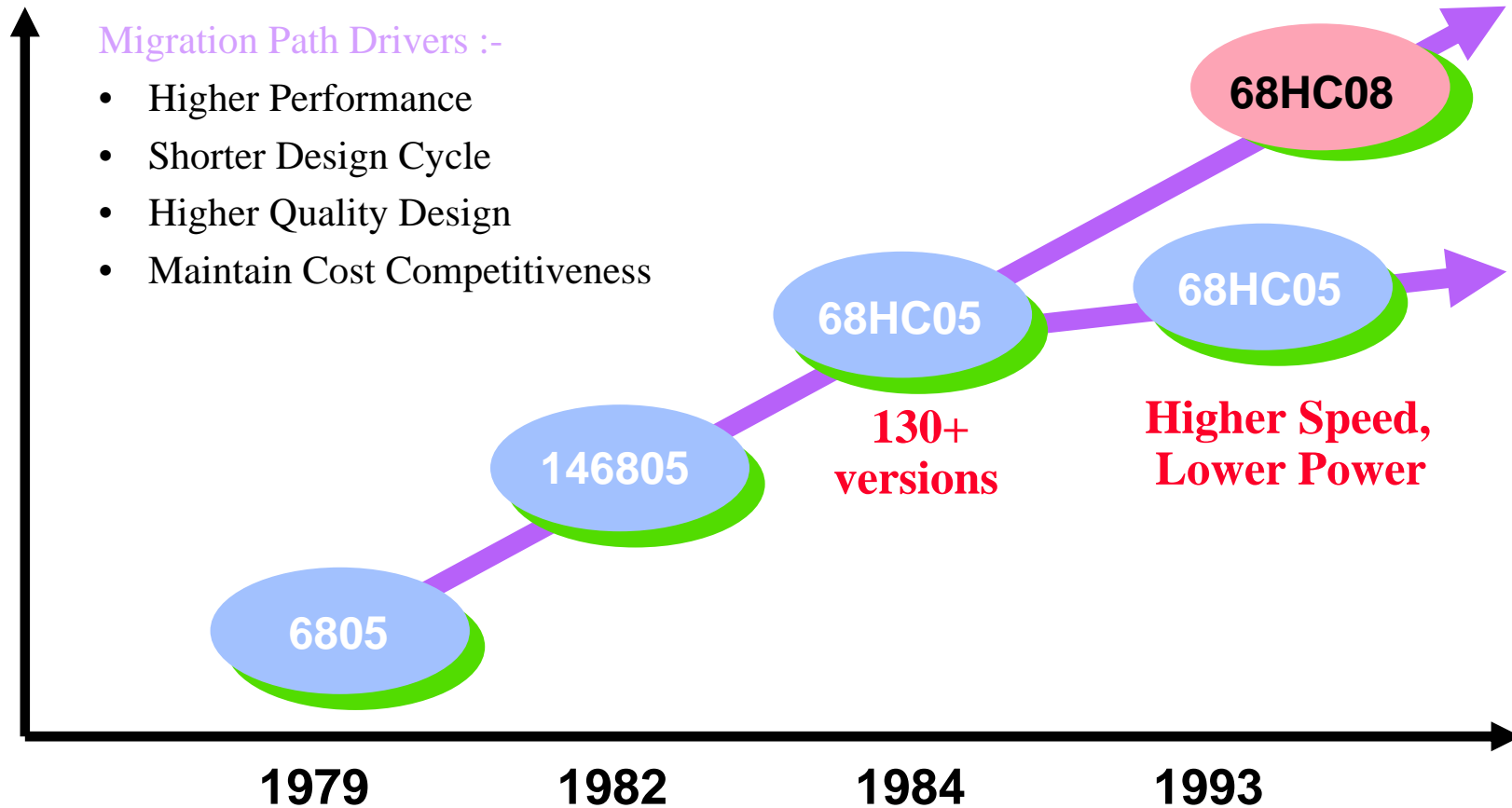

# Motorola MCU Evolution

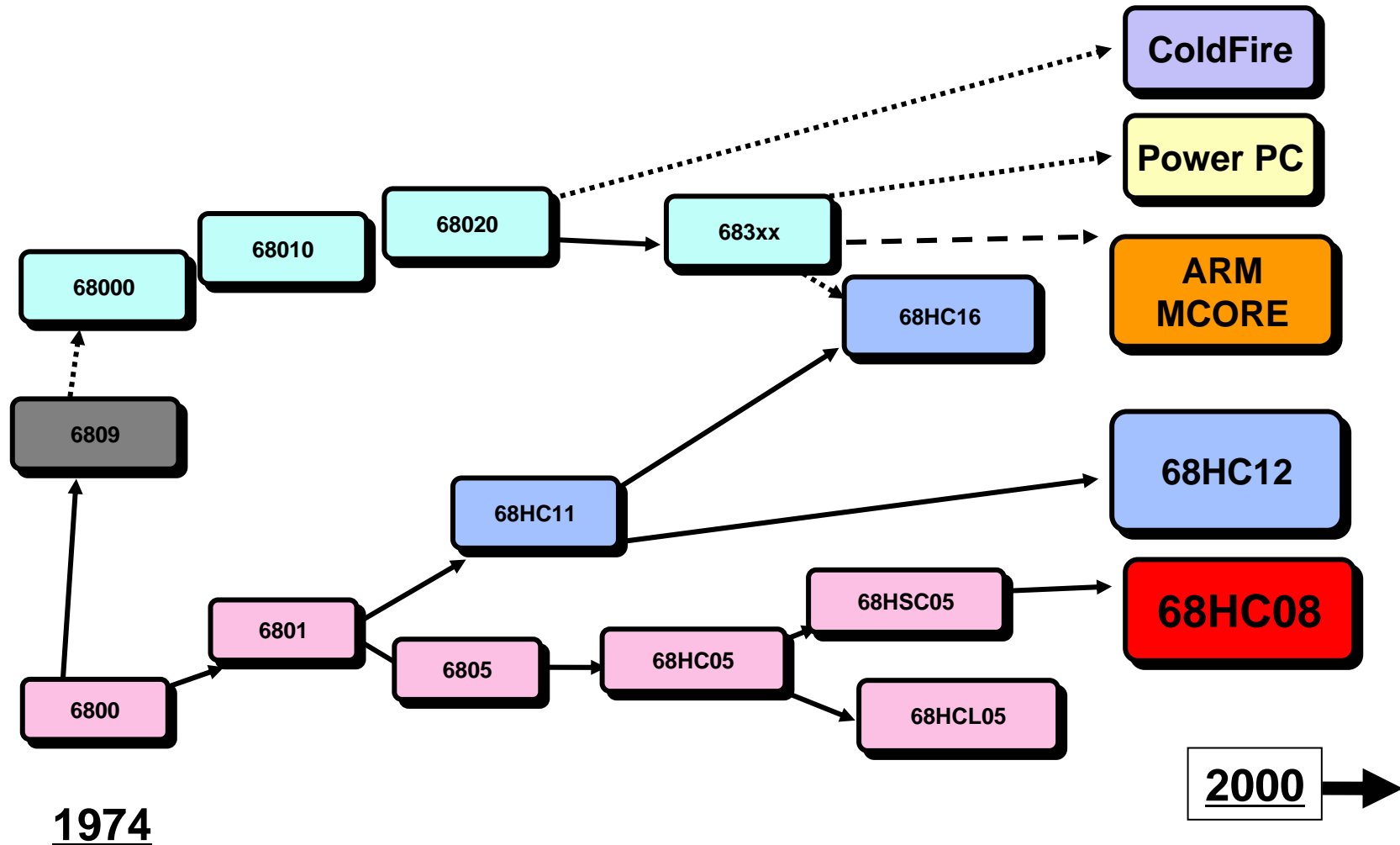

# MC68HC05, 08 CPU Structure

## Registers

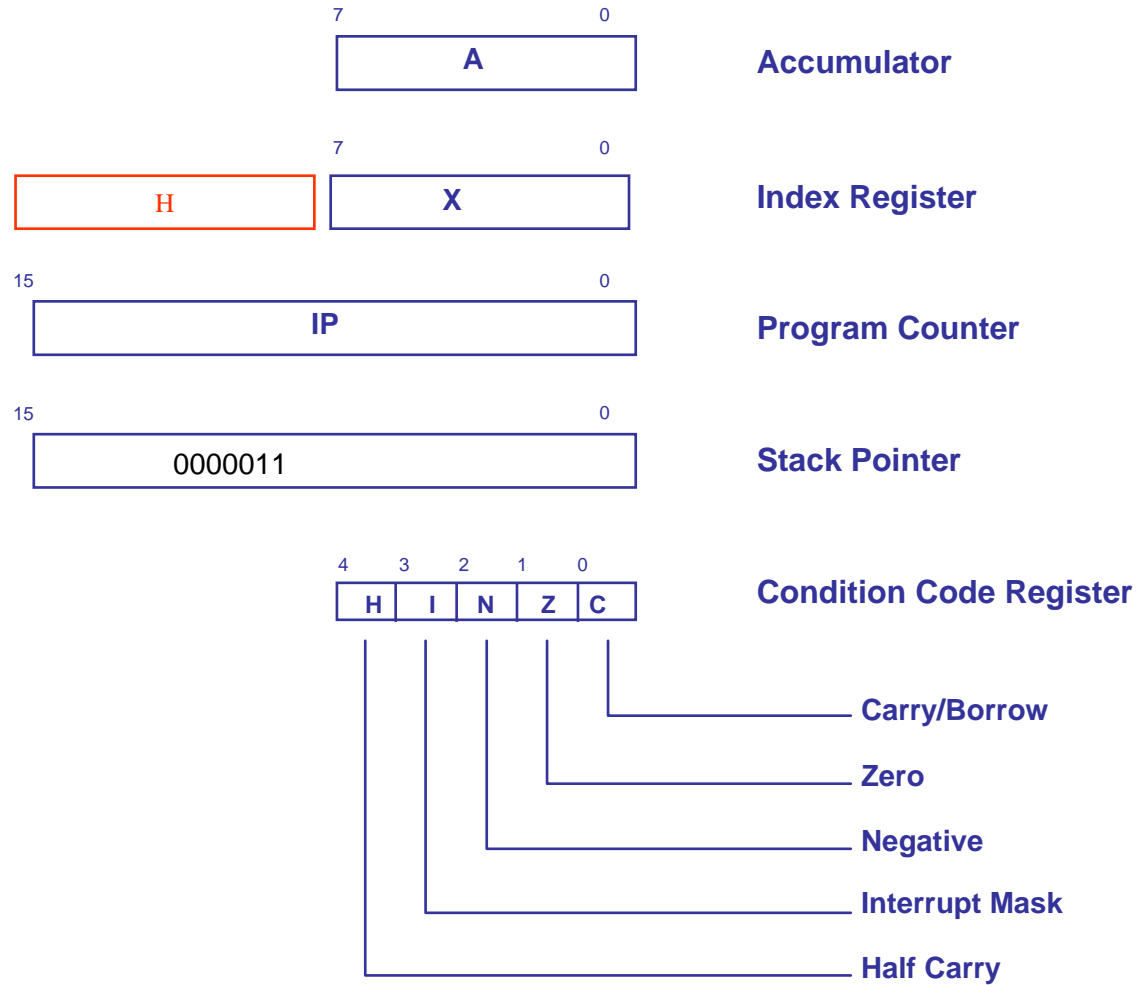

# HCS12 CPU

68HC11 = 68HC12 = HCS12 Programmers Model

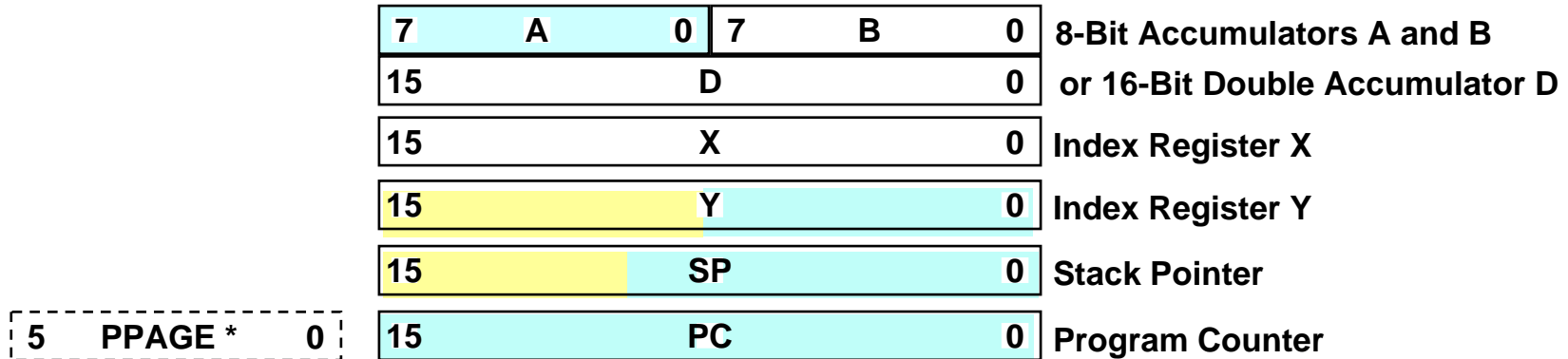

- ◆ Source code compatible
- ◆ Identical stack frame
- ◆ \* PPAGE used by CALL & Return To Call (RTC). (paged HC(S)12 only)

HC05 / HC08 / HCS12  
 HC08 / HCS12

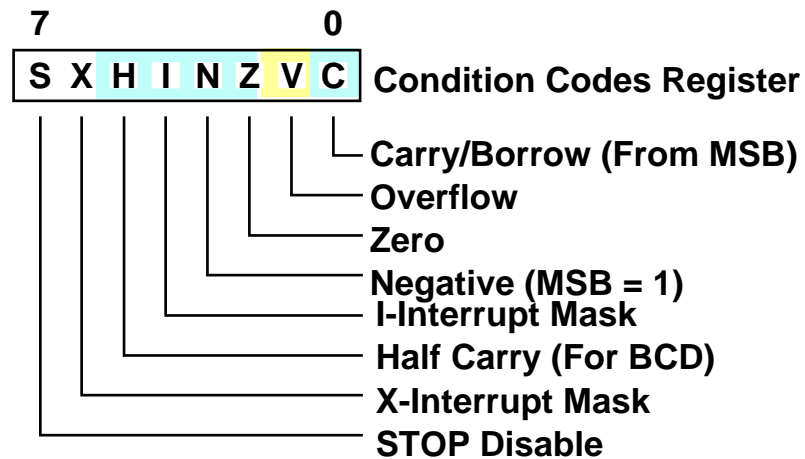

# MC68K, CPU32, ColdFire CPU Structure

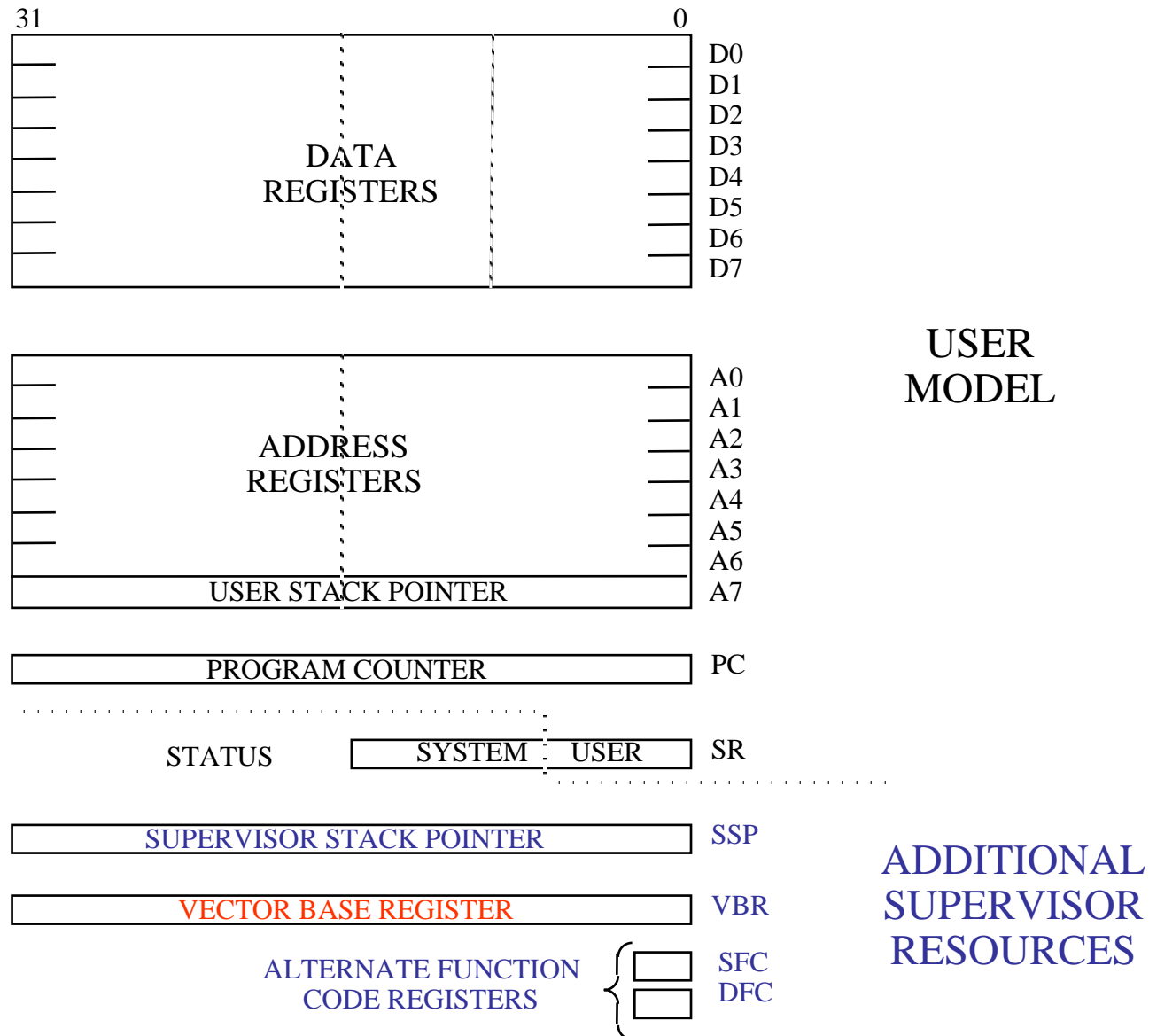

# Motorola Part Numbering Scheme

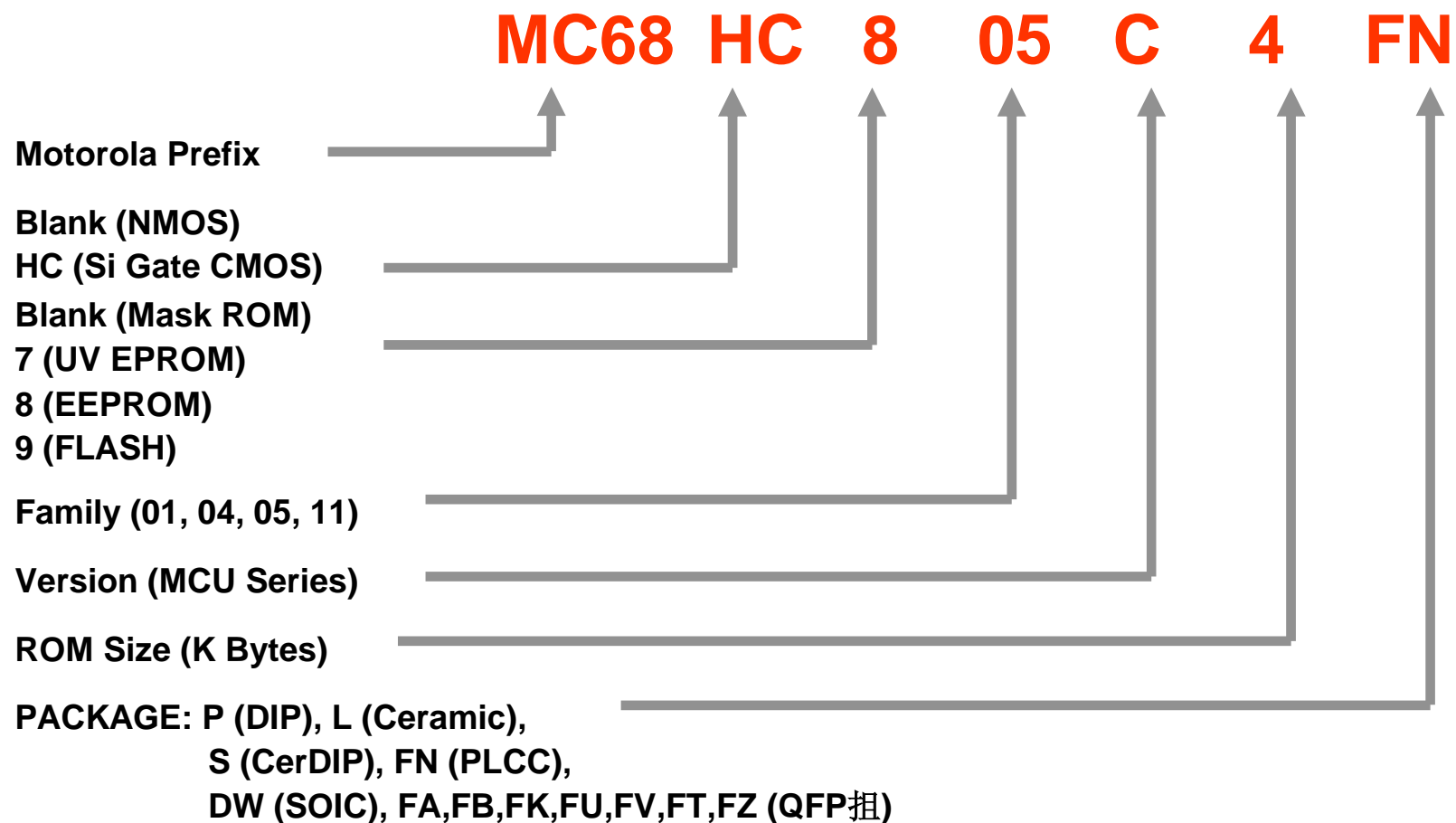

# HC05 family

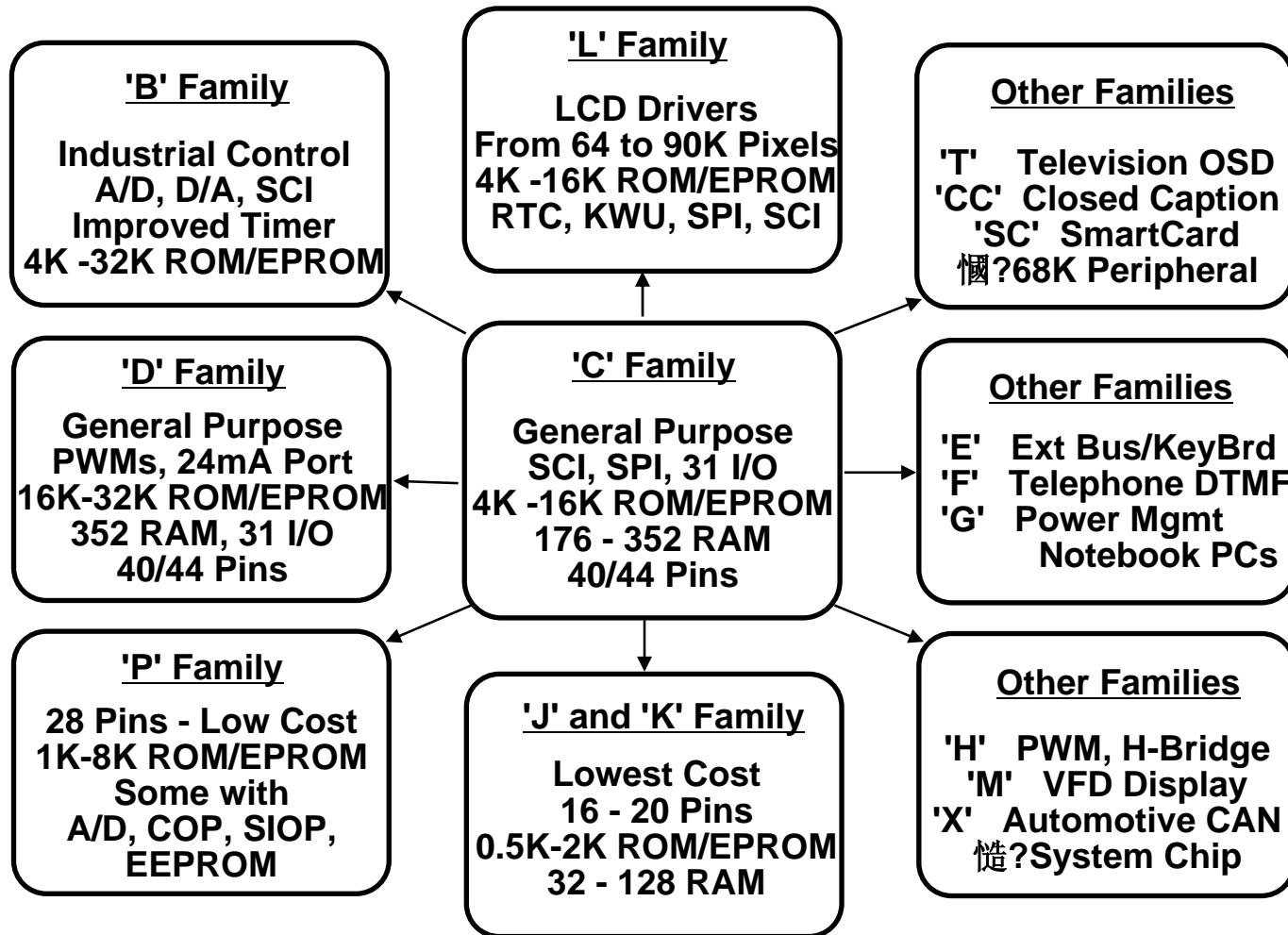

# HC05B family



## Industrial Control/Automotive MCU Applications

Device	ROM (bytes)	RAM (bytes)	EPROM (bytes)	EEPROM (bytes)	TIMER	I/O	SERIAL	A/D	PWM	COP	Package Options	OTP	Dev Sys	Comments
HC05B4	4K	176	4K	256	16 BIT 2 I/C, 2 O/C	32	SCI	8-CH 8-BIT	2-CH 8-BIT	1	56SDIP - B 52PLCC - FN	705B5	EVS	4k without EEPROM
HC705B5	4K	176	6K	256	16BIT 2 I/C, 2 O/C	32	SCI	8-CH 8-BIT	2-CH 8-BIT	1	56SDIP - B 52PLCC - FN	N/A	EVS	B6 EPROM emulation
HC05B6	6K	176	4K	256	16 BIT 2 I/C, 2 O/C	32	SCI	8-CH 8-BIT	2-CH 8-BIT	1	56SDIP - B 52PLCC - FN 64QFP - FU	705B5	EVS	Double speed 4MHz available!
HC05B8	8K	176	4K	256	16-BIT 2 I/C, 2 O/C	32	SCI	8-CH 8-BIT	2-CH 8-BIT	1	56SDIP - B 52PLCC - FN 64QFP - FU	705B16	EVS	4MHz available
HC05B16 (705B16)	16K (X)	352	X (16k)	256	16-BIT 2 I/C, 2 O/C	32	SCI	8-CH 8-BIT	2-CH 8-BIT	1	52PLCC - FN 64QFP - FU	705B16	EVS	
HC05B32 (705B32)	32K (X)	528	X (32k)	256	16-BIT 2 I/C, 2 O/C	32	SCI	8-CH 8-BIT	2-CH 8-BIT	1	52PLCC - FN 64QFP - FU	705B32	TBD	ROM sampling 1Q '94 705B32 adv. sampling

## Versatility of EEPROM with A/D, Serial, and PWMs

# HC05C family

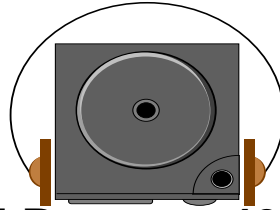

## General Purpose 40/44 Pin MCUs

Device	ROM (bytes)	RAM (bytes)	EPROM (bytes)	EEPROM (bytes)	TIMER	I/O	SERIAL	A/D	PWM	COP	Package Options	OTP	Status	Comments
<b>HC05CJ4 (705CJ4)</b>	4k (X)	224	X (4K)	☐	16-BIT 1 I/C, 1 O/C 15 stg MFT	31	SCI, SPI & slave IIC	☐	☐	☐	40 DIP - P 44 QFP - FB	705CJ4	Contact Sales	C4 +IIC+COP 10mA sink port
<b>HC05C0</b>	0	512	X	X	16-BIT 1 I/C, 1 O/C 15 stg MFT	18	SCI	X	X	☐	40 PDIP - P 42 - SDIP - B 44 PLCC - FN	Not needed	Contact Sales	16-bit external address, 8-bit data bus (mux or non mux), KBI
<b>HC05C4</b>	4K	176	☐	X	16-BIT 1 I/C, 1 O/C	31	SCI & SPI	☐	☐	☐	40 DIP - P 44 PLCC FN 44 QFP - FB 42 SDIP - B	705C8 (N/A)	Production	High speed & Low power
<b>HC05C4A* (705C8A*)</b>	4K (X)	176	X (8K)	☐	16 BIT 1 I/C, 1 O/C	31	SCI & SPI	☐	☐	☐	as HC05C4	705C8A (N/A)	Contact Sales	
<b>HC05C5 (705C5)</b>	5K (X)	176	X (5K)	128	16 BIT 1 I/C, 1 O/C	32	SIOP	☐	☐	☐	40 DIP - P 44 PLCC FN	705C5 (N/A)	Production	LVPI, 10mA capability on one 8 bit port.
<b>HC05C8 (705C8)</b>	8K (X)	176 (352)	X (8K)	☐	16-BIT 1 I/C, 1 O/C	31	SCI & SPI	☐	☐	☐	as HC05C4	705C8	Production	High speed option. Low power option.
<b>HC05C12</b>	12K	176	☐	☐	16-BIT 1 I/C, 1 O/C	31	SCI & SPI	☐	☐	☐	as HC05C4	705C9 no cop	Production	(HC05C4A features)
<b>HC05C9 [A] (705C9) [705D32A]</b>	16K (X) [(X)]	352	X (16K) [(32K)]	☐	16-BIT 1 I/C, 1 O/C	31	SCI & SPI	☐	☐	☐	as HC05C4	705C9 [TBD]	Production [contact Sales]	705C9 not in QFP 705D32A on hold

\* We have added some commonly asked for features to the HC05C family. The HC05C4A/C9A/C12 705C8A all have pull-up option on I/O, Keyboard wakeup, COP and high current port pin(25mA sink).

# HC05D family

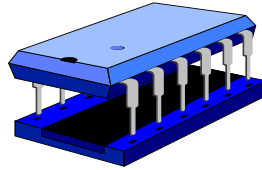

## General Purpose 40/44 Pin MCUs with PWMs

Device	ROM (bytes)	RAM (bytes)	EPROM (bytes)	EEPROM (bytes)	TIMER	I/O	SERIAL	A/D	PWM	COP	Package Options	OTP	Status	Comments
HC05D9 (HC705D9)	16K (X)	352	X (16K)		16 BIT 1 I/C, 1 O/C	32	SCI		5 ch 6-bit		40 DIP - P 44 PLCC -FN 44 QFP - FB	705D9	Production	24mA port driver
HC05D24	24K	352			16 BIT 1 I/C, 1 O/C	32	SCI		5 ch 6-bit		40 DIP - P 44 PLCC -FN		Production	24mA port driver
HC05D32 (HC705D32)	32K (X)	352	X (32K)		16 BIT 1 I/C, 1 O/C	32	SCI		5 ch 6-bit		40 DIP - P 44 PLCC -FN		Production (Contact Sales)	24mA port driver 705D32 on hold

# HC05E family

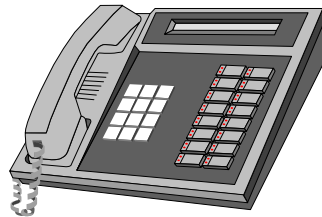

Device	ROM (bytes)	RAM (bytes)	EPROM (bytes)	EEPROM (bytes)	TIMER	I/O	SERIAL	A/D	PWM	COP	Package Options	OTP	Status	Comments
HC05E0	see comment	480	☐	☐	15 Stage Multi Function Timer	36	IIC	☐	☐	☐	68PLCC - FN	Not Needed	Production	64K ext. memory Keyboard interrupt
HC05E1 (705E1)	4K (X)	368	X (4K)	☐	15 Stage Multi Function Timer	20	☐	☐	☐	☐	28DIP - P 28SOIC - DW	705E1	Production	PLL, RTI , 15 stage multifunction timer
HC05E6 (705E6)	6k (X)	128	X (6k)	160	16 bit+15 stg 1 I/C, 1 O/C	36	☐	4 Ch 8-Bit	☐	☐	28 SOIC -DW 44 QFP - FB	N/A	Contact Sales	Keyb/d IRQ, LVI
HC05E16 (705E24)	16K (X)	352	X (24K)	320	16-bit + 15 stg 2 I/C, 2 O/C	47+ 2	IIC	2 Ch 8-Bit	☐	☐	64 QFP - FU 44 QFP - FB	N/A	Contact Sales	PLL, RTI, KBI

## HC05E0

- o External Memory
- o Double Internal Bus Speed (4MHz)
- o No MOQ

## HC(7)05E1

- o Originally Designed As A PC Mouse Microcontroller
- o PLL To Reduce External Oscillator Costs
- o Real Time Interrupts

- ☐ HC(7)05E6 / 16 / 24
- ☐ Originally Designed For Analog Telephone Applications
  - ☐ o Keyboard Wake-up
  - ☐ o Low Voltage Inhibit
  - ☐ o EEPROM For Permanent Memory Storage

# HC05H family

## Motor Control MCU Applications

Device	ROM (bytes)	RAM (bytes)	EPROM (bytes)	EEPROM (bytes)	TIMER	I/O	SERIAL	A/D	PWM	COP	Package Options	OTP	Status	Comments
HC05H2	2K	96	☐	☐	15 stage multi-function	16	SIOP	☐	2 ch 8-bit	☐	40DIP - P 42SDIP - B 44PLCC - FN	705H2	Contact Sales	RTI, PWM'S &, LDMOS (300mA)
HC705H2	☐	96	2K	☐	15 stage multi-function	16	SIOP	☐	2 ch 8-bit	☐	40DIP - P 42SDIP - B 44PLCC - FN	N/A	Contact Sales	RTI, PWM'S &, LDMOS (300mA)

### ☐ LDMOS

☐ The 68HC(7)05H2 incorporates 4 power output drivers capable of sinking or sourcing up to 300 mA. The power drivers can operate in the following modes:

☐ **Switch Mode:** 8 switching transistors allow direct static control of the 4 output pins.

☐ **Driver Mode:** 4 transistor pairs allow direct static control of the 4 output pins as standard high current drivers.

☐ **H-bridge Mode:** 2 H-bridges allow bidirectional current between the DPA and DMA pins and between the DPB and DMB pin

☐ Mode selection of the group A transistors is independent of the mode selection of the group B transistors.

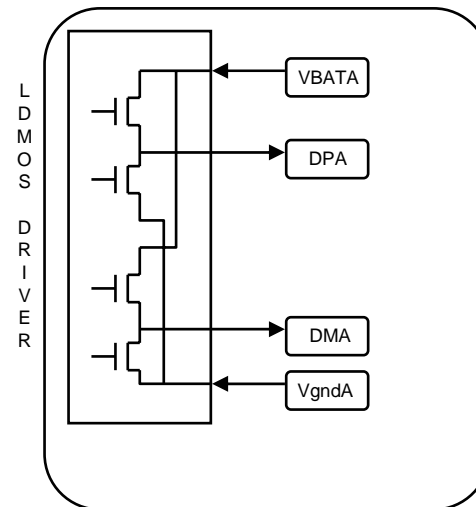

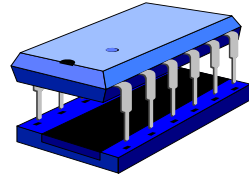

## HC05 I family

Device	ROM (bytes)	RAM (bytes)	EPROM (bytes)	EEPROM (bytes)	TIMER	I/O	SERIAL	A/D	PWM	COP	Package Options	OTP	Status	Comments
HC0518	8K	224	☐	☐	16 BIT 2 I/C, 1 O/C	42	2 x SCI	☐	☐	☐	64QFP - FU 68PLCC - FN 64SDIP - B	70518	Production	68000 family interface
HC70518	☐	224	8K	☐	16 BIT 2 I/C, 1 O/C	42	2 x SCI	☐	☐	☐	64QFP - FU 68PLCC - FN 64SDIP - B	N/A	Production	68000 family interface

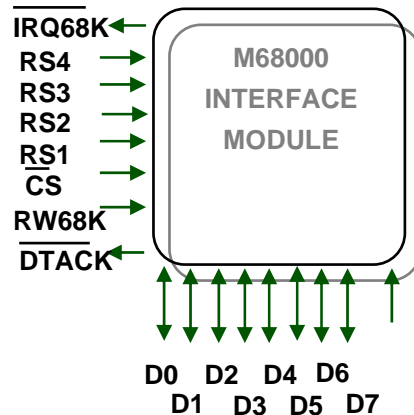

### 68HC0518

- M68000 Interface Module With 8-Bit Data Bus, 4 Register Select Lines & 4 Control Lines.
- M68000 Interface Module has four pairs of independent transmit and receive channels, each with a 4 byte asynchronous FIFO buffer.
- HC0518 Can Be Used As A Microcontroller That Uses A 68000 Family Member As A Slave Device Or As A Programmable Specialized Peripheral To A 68K System.

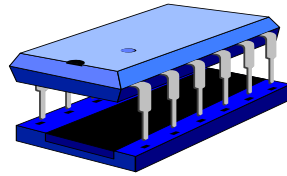

# HC05K family

## General Purpose 16 Pin MCUs

Device	ROM (bytes)	RAM (bytes)	EPROM (bytes)	EEPROM (bytes)	TIMER	I/O	SERIAL	A/D	PWM	COP	Package Options	OTP	Status	Comments
HC05K0	0.5K	32	☐	☐	15 stage multifunction timer	10	☐	☐	☐	☐	16DIP - P 16SOIC - DW	705K1	Production	
HC05K1	0.5K	32	64 bits	☐	15 stage multifunction timer	10	☐	☐	☐	☐	16DIP - P 16SOIC - DW	705K1	Production	personality EPROM
HC705K1	☐	32	0.5K + 64 bits	☐	15 stage multifunction timer	10	☐	☐	☐	☐	16DIP - P 16SOIC - DW	N/A	Contact Sales	personality EPROM
HC05K3	920	64	☐	128	15 stage multifunction timer	10	☐	☐	☐	☐	16DIP - P 16SOIC - DW	N/A	Contact Sales	personality EEPROM RTI,Keyboard scan

### □ Applications:

- Car alarms
- Power Windows
- Airbags
- Keyless entry
- PC mouse

# The J Family

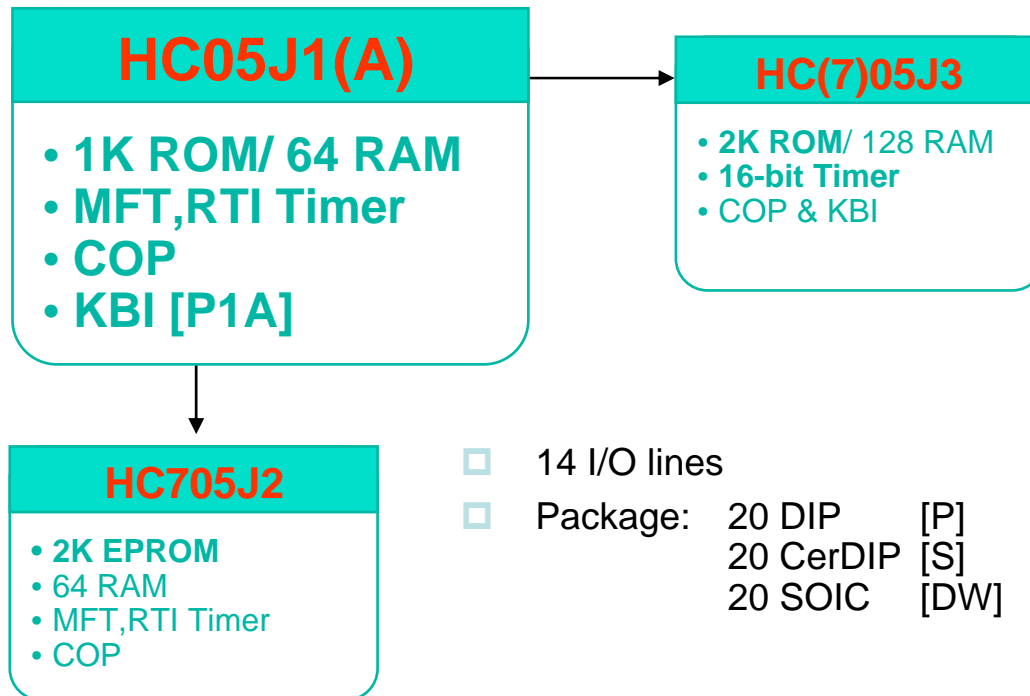

- 14 I/O lines
- Package: 20 DIP [P]  
20 CerDIP [S]  
20 SOIC [DW]

## Applications :-

- **20-pin Low Cost General Purpose MCU**
- **Examples :-**
  - Mouse or Trackball
  - IR Remote Control Unit
- **Special Options**
  - High Speed(4MHz Bus Clock)  
MC68HSC05J1A
  - Low Voltage  
(1.8V min. at 500KHz Bus Clk.)  
MC68HCL05J1A

# The Spider - MC68HC(7)05SR3

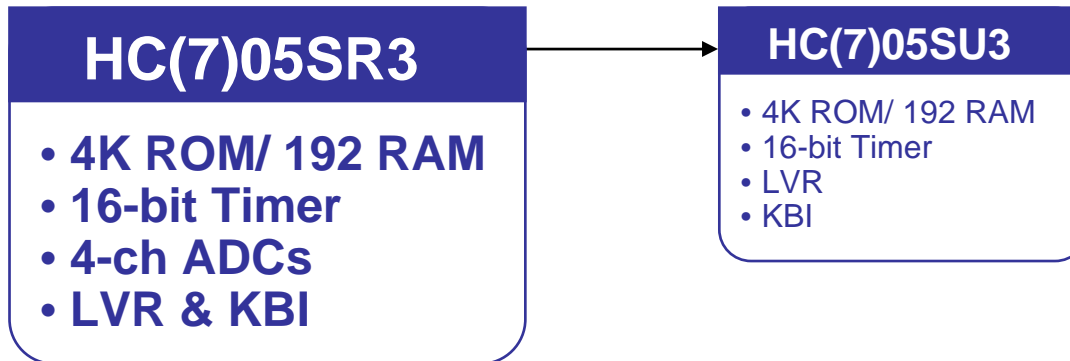

- **Upgrade from NMOS MC6805R3**
- **3.3V to 5.0V Operating Range**
- **32 I/O lines**
- **2 MHz Bus Clock**
- **Package:** 40 DIP [P]  
44 QFP [FB]  
42 SDIP [B]

## Applications :-

- **General Purpose MCU**
- **Examples :-**
  - baserset of coreless phone (P1 in handset)
  - answering machine
  - pager
  - home appliances (washing machine, air conditioner, microwave oven)
  - computer (keyboard - SU3)

# Application Example: Fuzzy Logic Rice Cooker

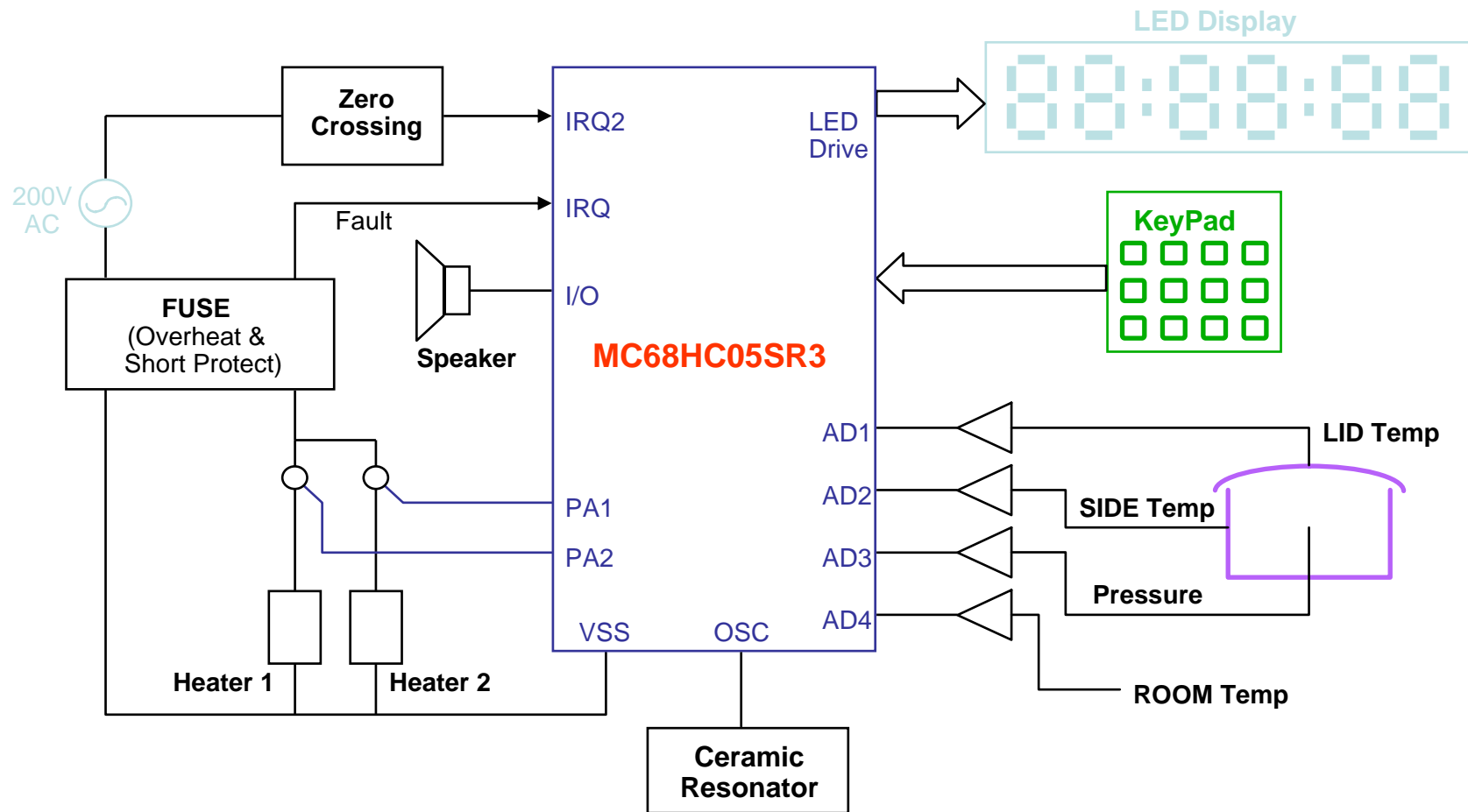

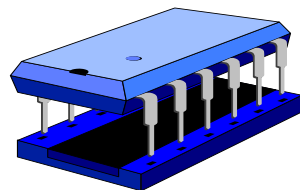

# HC05P family

## General Purpose 28 Pin MCUs

Device	ROM (bytes)	RAM (bytes)	EPROM (bytes)	EEPROM (bytes)	TIMER	I/O	SERIAL	A/D	PWM	COP	Package Options	OTP	Status	Comments
HC05P1[A]	2K	128	☐	☐	16 BIT 1 I/C, 1 O/C	21	☐	☐	☐	☐	28 DIP - P 28 SOIC- DW	705P9	Production	☐?version sampling High current pin, KBI
HC05P2	3K	96	☐	☐	15-stage multifunction	22	IIC	☐	☐	☐	28 DIP - P 28 SOIC- DW 32 PLCC- FN		Production	
HC05P3 (705P3)	3K (X)	128	X (6K)	128 (160)	16 BIT I/C, O/C & 15 stg MFT	22	☐	X	☐	☐	28 DIP - P 28 SOIC- DW	705P3	Production (Contact Sales)	Keyboard interrupt
HC05P4	4K	176	☐	☐	16 BIT 1 I/C, 1 O/C	21	SIOP	☐	☐	☐	as above	705P6	Production	mask option cop
HC05P5	3K	128	☐	☐	16 BIT 1 I/C, 1 O/C	21	☐	see comment	2 ch 8 bit	☐	as above	☐	Production	Voltage Comparator
HC05P6 (705P6)	4.5K (X)	176	X (4.5)	☐	16 BIT 1 I/C, 1 O/C	21	SIOP	4 CH 8-BIT	☐	☐	as above	705P6 (X)	Production	
HC05P7	2K	128	☐	☐	16 BIT 1 I/C, 1 O/C	21	SIOP	☐	☐	☐	as above	705P9	Production	
HC05P8	2K	112	☐	32	15 stage multifunction	20	SIOP	4 CH 8 BIT	☐	☐	as above	Piggy Back	Production	LVI option
HC05P9 (705P9)	2K (X)	128	X (2K)	☐	16 BIT 1 I/C, 1 O/C	21	SIOP	4 CH 8 BIT	☐	☐	as above	705P9 (N/A)	Production	
HC05P10	4K	128	☐	☐	16 BIT 1 I/C, 1 O/C	21	SIOP	☐	☐	☐	as above	705P9 (2K)	Contact Sales	pull-up resistor, high current on port
HC05P15	3K	128	64 bits	☐	16 BIT 1 I/C, 1 O/C	21	☐	see comment	2 ch 8 bit	☐	as above	☐	Production	Voltage Comparator
HC05PE0	2K	128	☐	☐	16 BIT 1 I/C, 1 O/C	20	☐	☐	☐	☐	as above	☐	Samples	20mA sink pin, KBI, PEP (64 bits)

- ☐ Designed Into..
- ☐ Electronic Sunroof, Cordless Phone, Smoke Detectors, PC Mouse, Car Radio, CD Player.....

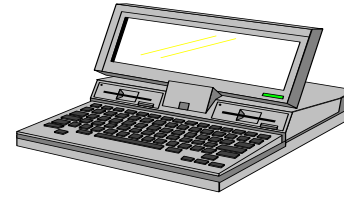

# HC05G family

## PC Power Management MCU Applications

Device	ROM (bytes)	RAM (bytes)	EPROM (bytes)	EEPROM (bytes)	TIMER	I/O	SERIAL	A/D	PWM	COP	Package Options	OTP	Status	Comments
HC05G1 (705G1)	8K (X)	176	X (8K)	☐	16 BIT 1 I/C, 1 O/C RTC	48	SPI	4 Ch 8- Bit	☐	☐	56 SDIP - B 64 QFP - FU	705G1	Production	32 Khz PLL
HC05G3 (705G4)	24K (X)	768	X (32K)	☐	16 BIT 1 I/C, 1 O/C 8-bit Event Cntr	68	Dual SPI	8 Ch 8- Bit	4 Ch 8- Bit	☐	80 QFP - FU	705G4	Production	KBI, Dual Osc Dual IRQ
HC05G9 (705G9)	12K (X)	304	X (12K)	☐	15 stage multi- function timer RTC, tick timer	64	Dual SIO	8 Ch 8- Bit	4 Ch 8- Bit	☐	160 QFP - FT	705G9	Production	KBI, key scan, IDE, 32Khz PLL, host addr decoder, PIO, chp se
HC05G10 (705G10)	12K (X)	304	X (12K)	☐	15 stage multi- function timer RTC, tick timer	62	☐	5 Ch 8- Bit	4 Ch 8- Bit	☐	100 QFP - FU	705G10	Production	KBI, key scan, IDE, 32Khz PLL, host addr decoder, 4 chip select

Motorola has developed HC05G9/G10 demonstration software that can be customized to produce a working PC compatible notebook/laptop computer. The HC05G9 can be used to replace many standard parts in a conventional PC. The HC05G9 and our demonstration software replaces: RTC (MC146818), keyboard controller (8042/8048), battery & power management, PWM to control Brightness/contrast/volume/alarm and hard disk controller.

# Application Example: G1 in Air Conditioner

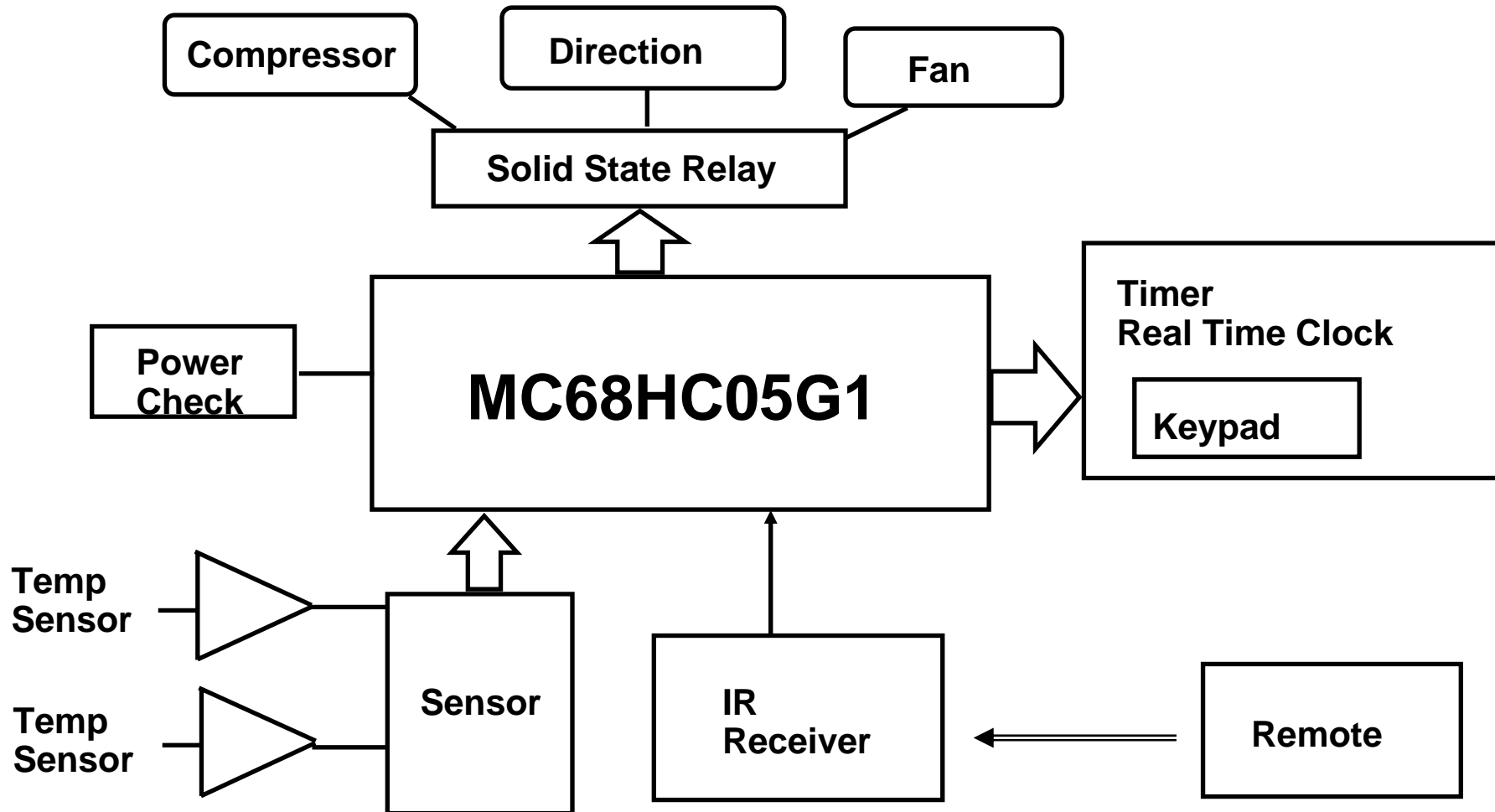

# The L Family

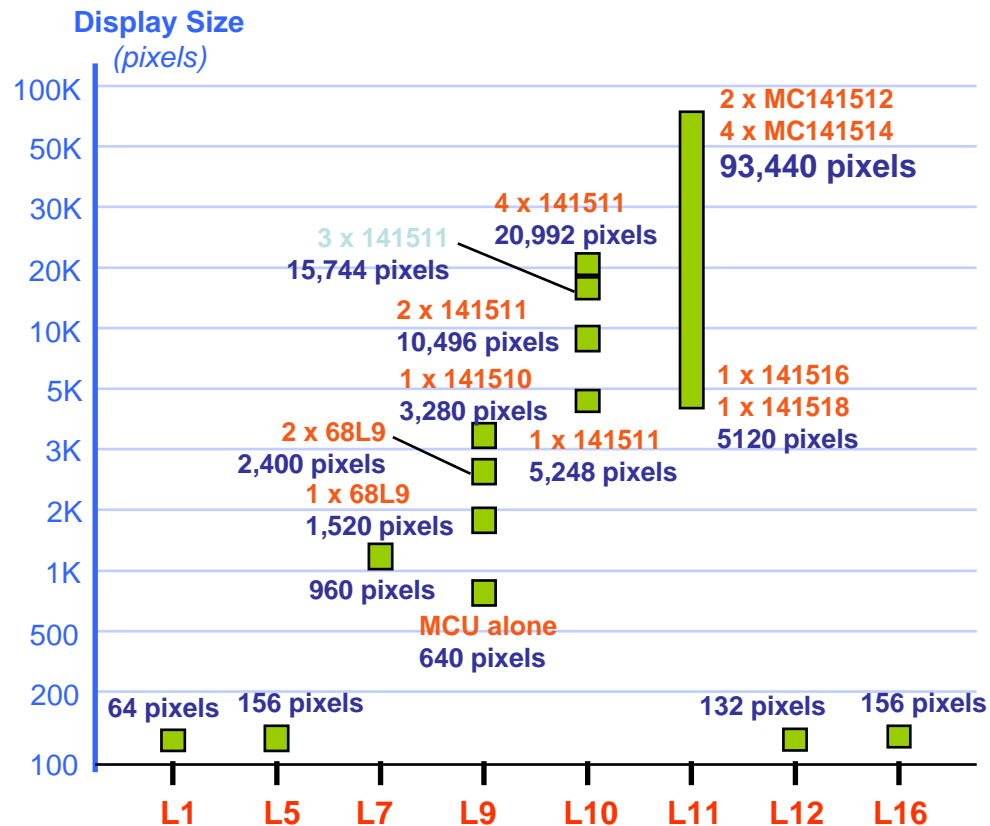

## MCU with LCD Module

- External Memory access Capabilities
  - L7            16K bytes
  - L9            64K bytes
  - L10          1M bytes
- Various Peripherals
  - 16-bit Timer(w 1 IC & 1 OC)
  - SCI
  - RTC
  - KBI
  - Tone Generator
- Applications
  - Numeric, Alpha-numeric & Chinese Pagets
  - Organizers & Electronic Diaries
  - Electronic Meters
  - LCD Games
  - Education Computers

# MC68HC05L11 (DragonKat II)

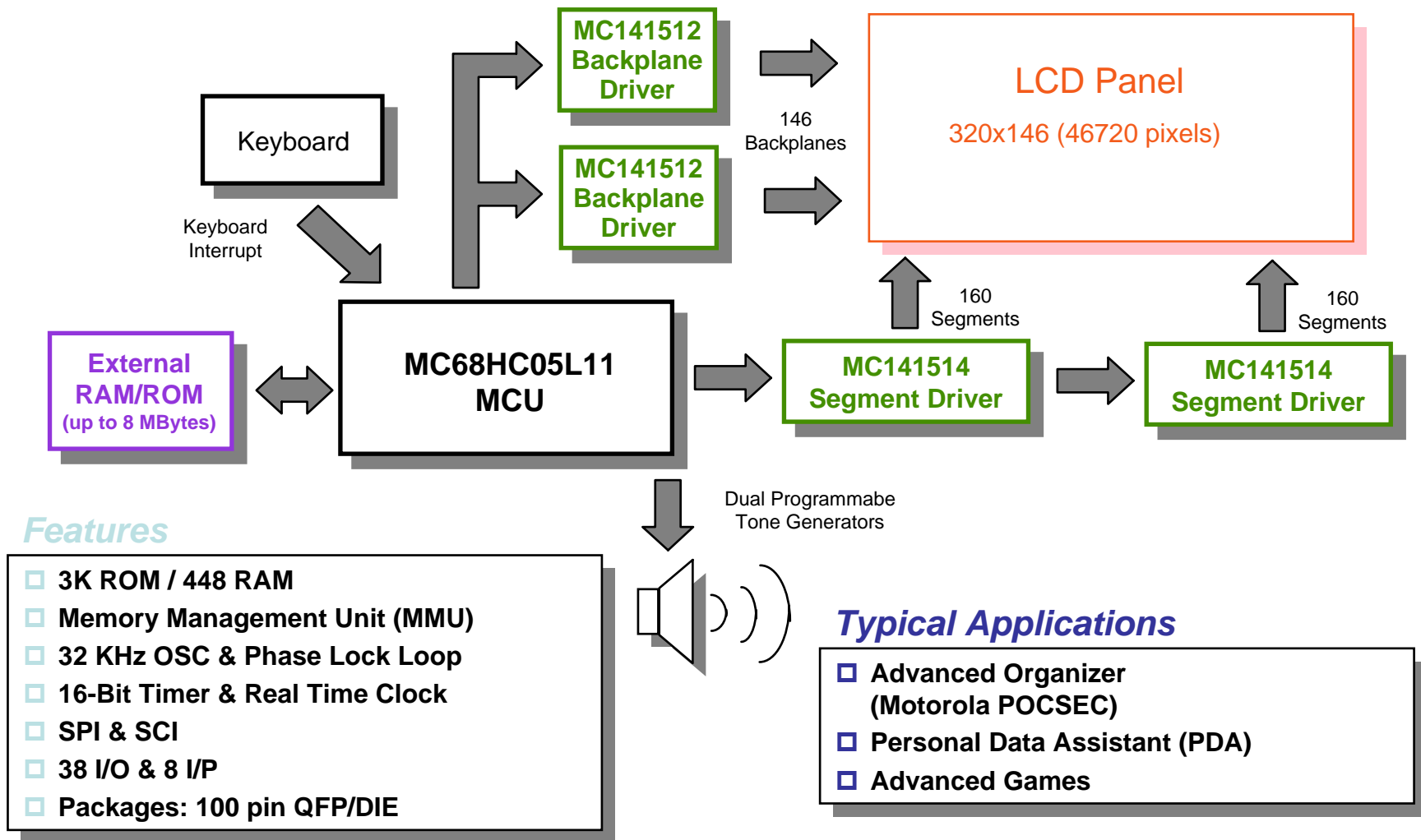

## Features

- ❑ 3K ROM / 448 RAM
- ❑ Memory Management Unit (MMU)
- ❑ 32 KHz OSC & Phase Lock Loop
- ❑ 16-Bit Timer & Real Time Clock
- ❑ SPI & SCI
- ❑ 38 I/O & 8 I/P
- ❑ Packages: 100 pin QFP/DIE

## Typical Applications

- ❑ Advanced Organizer (Motorola POCSEC)
- ❑ Personal Data Assistant (PDA)
- ❑ Advanced Games

# Application Example: Pager

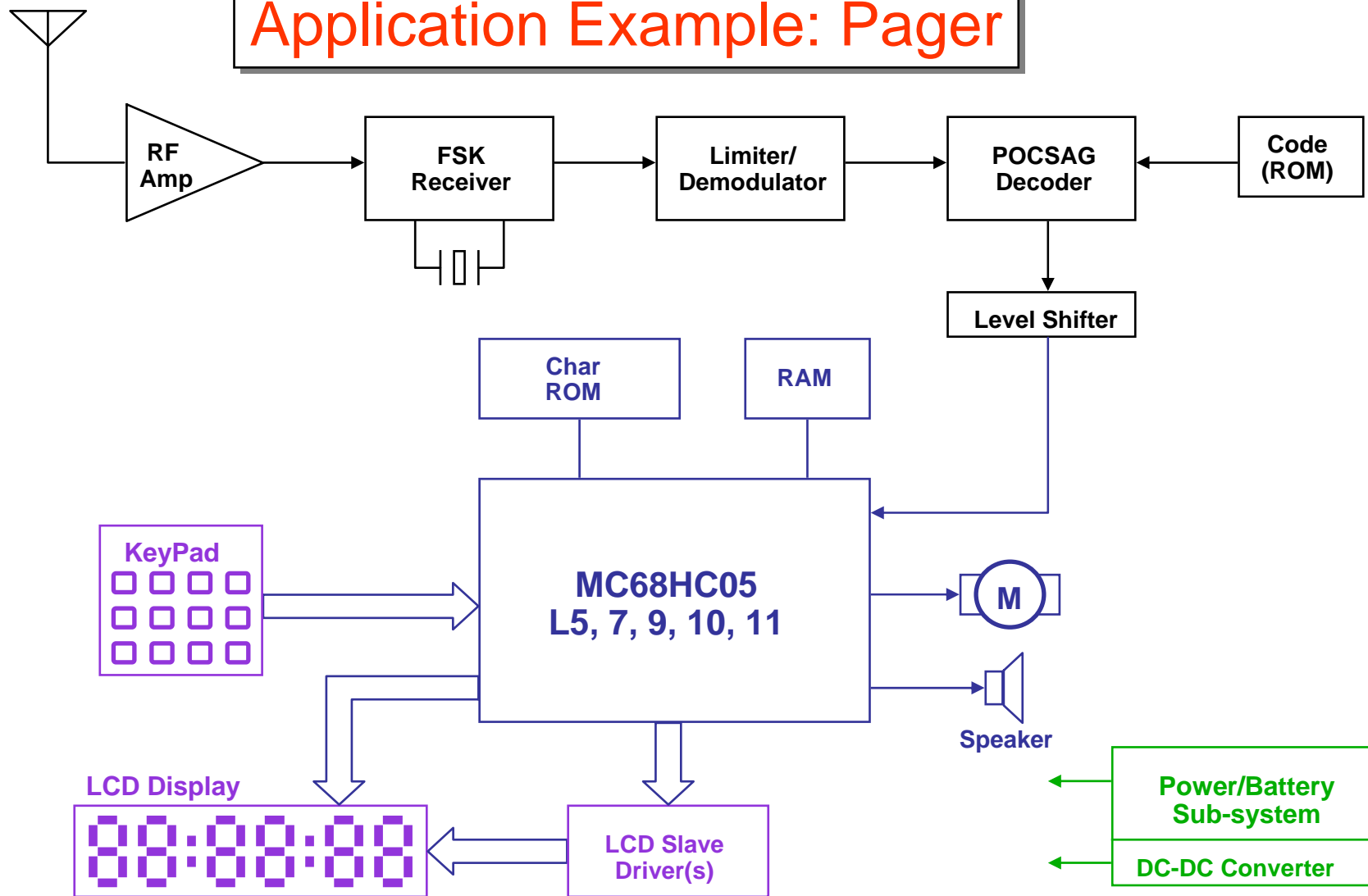

HC05M family

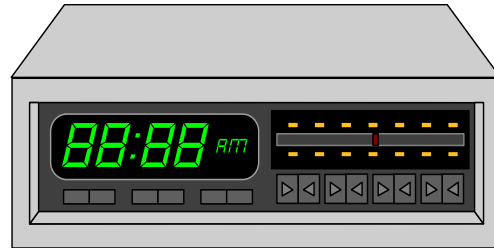

## Vacuum Florescent Display MCU Applications

Device	ROM (bytes)	RAM (bytes)	EPROM (bytes)	EEPROM (bytes)	TIMER	I/O	SERIAL	A/D	PWM	COP	Package Options	Status	Comments
HC05M4	4K	128	☐	☐	16 BIT 1 I/C, 1 O/C 8-bit mod	32 + 8	☐	6 ch 8 bit	☐	☐	52PLCC - FN	Contact Sales	High voltage Vacuum Florescent Drive (VFD)
HC05M6	7K	208	☐	☐	16 BIT 1 I/C, 1 O/C 15 stg MFT	50	☐	☐	☐	☐	64SDIP - B 68PLCC - FN 64QFP - FU	Production	High voltage Vacuum Florescent Drive (VFD)

### ☐ HC05M4, M6

☐ The high voltage ability of the Vacuum Florescent drives are capable of controlling the **-40 volts** required to operate standard **VFD displays**.

# HC05F family

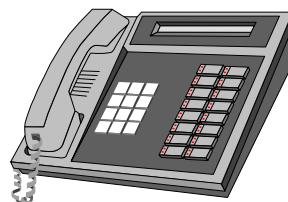

## Telephone and Answering Machine Applications

Device	ROM (bytes)	RAM (bytes)	EPROM (bytes)	EEPROM (bytes)	TIMER	I/O	SERIAL	A/D	PWM	COP	Package Options	OTP	Status	Comments
HC05F2	2K	288	☐	☐	16 BIT 1 I/C, 1 O/C	26	☐	☐	☐	☐	42SDIP - B 44QFP - FB	705F6	Production	DTMF, LED drive
HC05F4 (705F4)	4K (X)	256	X (8K)	256	16 BIT 2 I/C, 2 O/C	32	☐	☐	☐	☐	44QFP - FB 28 SOIC - DW 28 DIP - P 44 PLCC - FN	705F4	Contact Sales	DTMF, K/b IRQ 8 open drain inputs
HC05F5	5.5K	224	☐	☐	15 Stage multi function timer	30	☐	☐	☐	☐	40 DIP - P 44 PLCC - FN	Piggy Back	Production	DTMF receiver, RTI
HC05F6 (705F6)	4.6K (X)	320	X (4.6K)	☐	16 BIT 1 I/C, 1 O/C	26	☐	☐	☐	☐	42SDIP - B 44QFP - FB (64QFP - FU)	705F6	Production	DTMF, LED drive
HC05F8	8K	320	☐	☐	2 x16 BIT 1 I/C, 1 O/C	50	SPI	☐	☐	☐	64 QFP - FU	705F8	Production	DTMF, LED, K/b IRQ Manchester enc/dec
HC05F12	12k	384	☐	256	16 Bit+15 stg 3 I/C, 3 O/C	50	☐	☐	☐	☐	100 QFP - FU	705F32	Contact Sales	DTMF, K/b IRQ, LCD 32 x 4 (128 seg)
HC05F32 (705F32)	32k (X)	924	X (32k)	256	16 Bit+15 stg 4 I/C, 4 O/C	80	SPI SCI	4 Ch 8- Bit	3 Ch 8- Bit	☐	100 QFP - FU	705F32	Contact Sales	DTMF, K/b IRQ, RTI LCD 40 x 4 (160seg), LVI

- ❑ **DTMF**
- ❑ **The HC05F family's DTMF / melody generator is a multi-functional tone generator supporting DTMF dialing, melody-on-hold, and pacifier tone functions.**
- ❑ **The 68HC05F5 incorporates a DTMF receiver utilizing switched capacitor filters: a pre-emphasis filter for high frequency gain and eight bandpass filters for final frequency selection.**

# Application Example: F8 in Cordless Phone

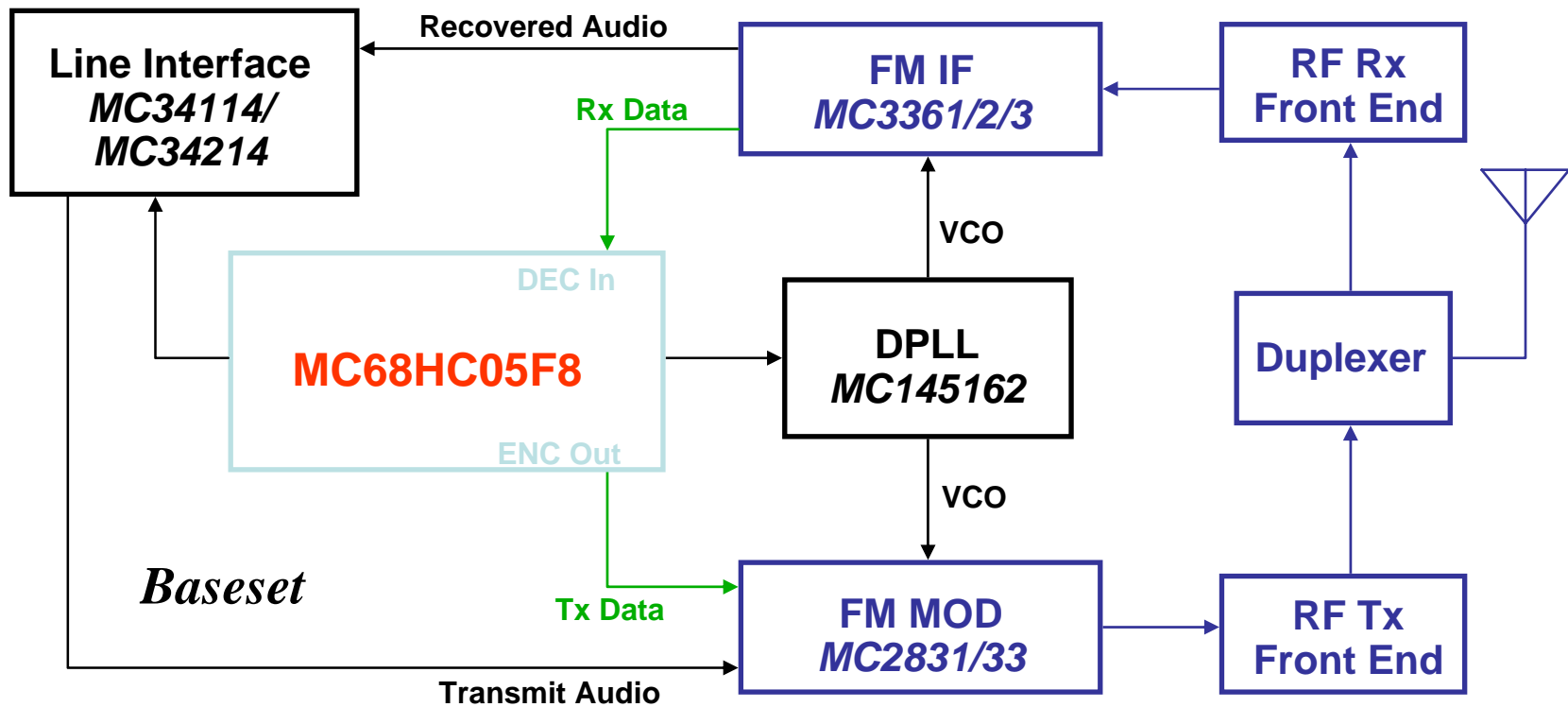

- Manchester Encoder/Decoder for Digital Code Processing
  - avoid voice will be mistaken as command

# HC05T/CC families

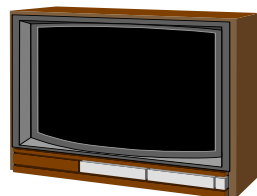

## Television On Screen Display and Closed Captioning Applications

Device	ROM (bytes)	RAM (bytes)	EPROM (bytes)	TIMER	I/O	SERIAL	A/D	PWM	COP	Package Options	OTP	Status	Comments
HC05CC1	16K	544	☐	16 Bit	31	SIOP IIC master	☐	8 Ch 6 Bit	☐	40 DIP - P	☐	Production	OSD + 4Mhz Closed Caption
HC05T1 HC05T2	8k 16K	320	☐	16 BIT 1 I/C, 1 O/C	30	SIOP	1 Ch 6 Bit	9 Ch 6 Bit	☐	40 DIP - P 42 SDIP - B	705T3	Production	OSD system
HC05T3 (705T3)	24K (X)	512	X (24K)	16 BIT 1 I/C, 1 O/C	29	SIOP	1 Ch 6 Bit	9 Ch 6 Bit	☐	40 DIP - P	705T3	Production	OSD system 112 Character Set
HC05T4 (705T4)	5K (X)	96	X (5K)	16 BIT 1 I/C, 1 O/C	17	☐	1 Ch 4 Bit	see comments	☐	42 SDIP - B	705T4	Production	OSD system 5 CH 6 BIT PWM 1 CH 14 BIT PWM
HC05T7	8K	320	☐	16 BIT 1 I/C, 1 O/C	28	IIC	1 Ch 8 Bit	see comments	☐	56 SDIP - B	705T10	Production	OSD system 8 CH 6 BIT PWM 1 CH 14 BIT PWM
HC05T10 (705T10)	12K (X)	320	X (12K)	16 BIT 1 I/C, 1 O/C	28	IIC	1 Ch 8 Bit	see comments	☐	56 SDIP - B	705T10	Production	OSD system 8 CH 6 BIT PWM 1 CH 14 BIT PWM
HC05T12 (705T12)	8K	320	☐	16 BIT 1 I/C, 1 O/C	36	IIC	1 Ch 4 Bit	see comments	☐	56 SDIP - B	705T12	Production	OSD system 8 CH 6 BIT PWM 1 CH 14 BIT PWM
HC05T32	32K	512	☐	16 BIT 1 I/C, 1 O/C	29	SIOP	1 Ch 6 Bit	9 Ch 6 Bit	☐	40 DIP - P	see comment	Contact Sales	HC05T3 with 32k OTP suggest 705T3

- **OSD:** The HC05T family incorporate on screen display, A/D (Remote control input) & PWM (volume adjustment, contrast, etc.). The On Screen Display systems provide multi-color display capabilities. OSD character set of up to 112 characters can be stored in ROM with a display grid of 18 x 10.

# Application Example

## System Block Diagram of a TV Set with TV MCU

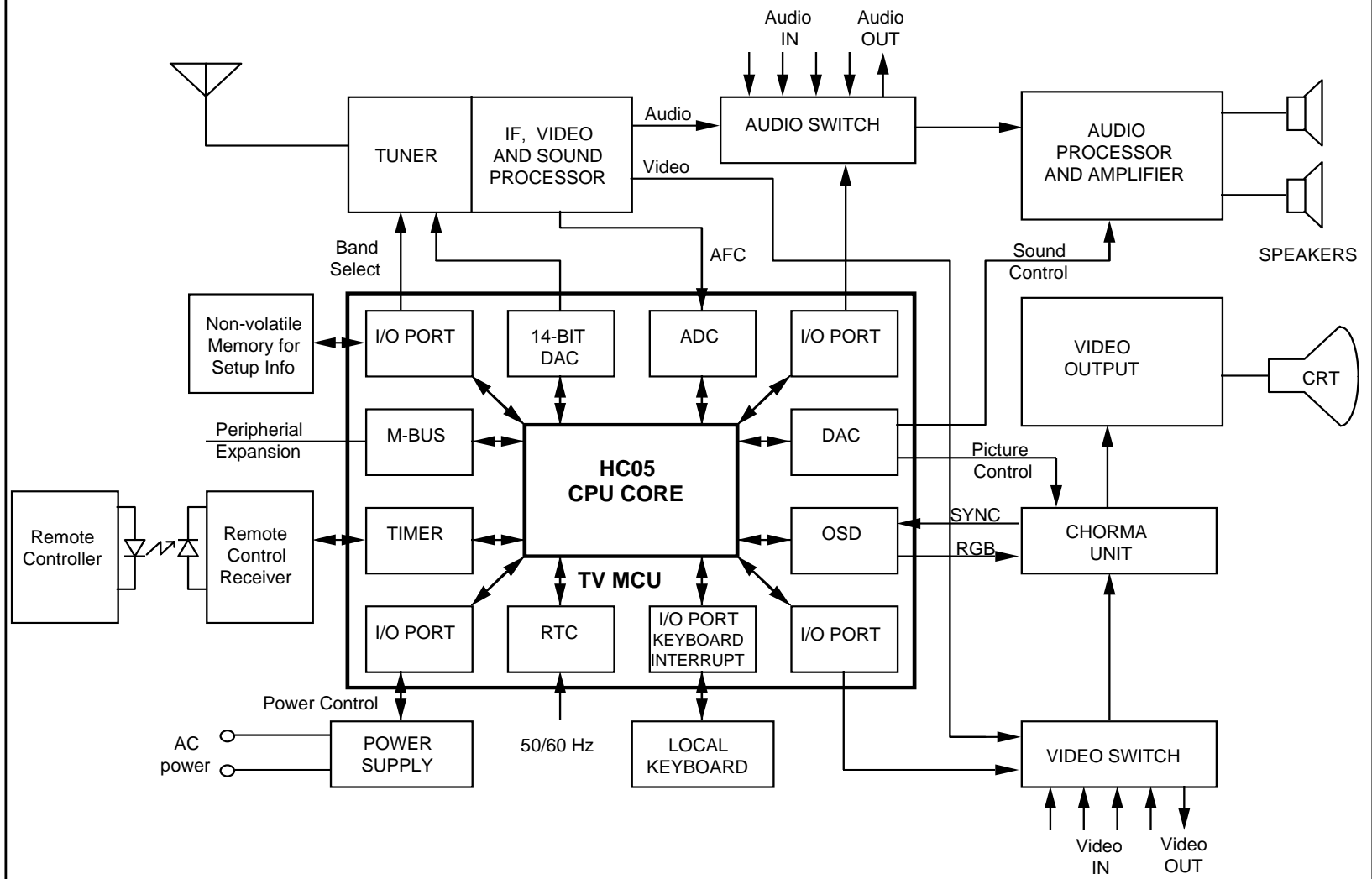

# HC05BD family

## □ Video Monitor MCU Applications

<b>HC05BD6</b>	6K	256 + 256	X	256	15 stg multi- funtion timer	50	X	4-CH 8-BIT	7ch 6-bit 8ch 8-bit	☐	56 SDIP - B	N/A	EVS	available 1Q 94
<b>HC705BD8</b>	☐	256 + 256	8k	256	15 stg multi- funtion timer	50	☐	4-CH 8-BIT	7ch 6-Bit 8ch 8-Bit	☐	56SDIP - B	N/A	EVS	EPROM Sampling now

# HC05V/X family



## Automotive/Industrial Mux MCU Applications

Device	ROM (bytes)	RAM (bytes)	EPROM (bytes)	EEPROM (bytes)	TIMER	I/O	SERIAL	A/D	PWM	COP	Package Options	OTP	Status	Comments
HC705V8	X	512	12K	128	16 bit	22	J1850 SPI	16 ch 8 bit	6 bit	☐	56 SDIP - B 68 PLCC - FN 64 QFP - FU	N/A	Samples	26V to 5V regulator J1850 MUX
HC05X1	12k	336	☐	☐	16 Bit +15 stg 1 I/C, 2 O/C	24	SSI J1850	☐	☐	☐	44 PLCC- FN	☐	Production	SAE J1850 Presently exclusive
HC05X4	4K	176	☐	☐	16 BIT 1 I/C, 1 O/C	16	X CAN	☐	☐	☐	28 SOIC - DW	705X4	Production	CAN module
HC705X4	☐	176	4K	☐	16 BIT 1 I/C, 1 O/C	16	X CAN	☐	☐	☐	28 SOIC - DW	N/A	Production	CAN module
HC05X16	16K	352	☐	256	16 BIT 2 I/C, 2 O/C	32	SCI CAN	8 CH 8 BIT	2 CH 8 BIT	☐	68 PLCC - FN 64 QFP - FB	705X16	Production	HC05B16 with CAN
HC705X16	☐	352	15K	256	16 BIT 2 I/C, 2 O/C	32	SCI CAN	8 CH 8 BIT	2 CH 8 BIT	☐	68 PLCC - FN 64 QFP - FB 68 CLCC - FS	N/A	Samples	HC705B16 with CAN
HC705X32	32K	352	5	256	16 BIT 2 I/C, 2 O/C	32	SCI CAN	8 CH 8 BIT	2 CH 8 BIT	☐	68 PLCC - FN 64 QFP - FB 68 CLCC - FS	N/A	Advanced Samples	32k HC05X16

- ☐ **MUX:**The HC05X family has built in multiplexing capability specifically designed (although not exclusively) for the automotive market. The Controller area network (CAN) module found on the HC05X4 and HC05X16 is a two wire (plus gnd) communication protocol that is designed to cut down the cost and weight of wiring looms within the automobile.



# HC05SC family

## Secure Smartcard MCUs

Device	ROM (bytes)	RAM (bytes)	EPROM (bytes)	EEPROM (bytes)	TIMER	I/O	SERIAL	A/D	PWM	COP	Package Options	Status	Comments
6805SC01	1.6K	36	1K	☐☐	☐☐	1	☐☐	☐☐	☐☐	☐☐	contact factory	Production	Security
HC05SC11	6K	128	8K	☐☐	☐☐	5	☐☐	☐☐	☐☐	☐☐	contact factory	Production	Security
HC05SC21	6K	128	☐☐	3K	☐☐	5	☐☐	☐☐	☐☐	☐☐	contact factory	Production	Security
HC05SC24	3K	128	☐☐	1K	☐☐	5	☐☐	☐☐	☐☐	☐☐	contact factory	Production	Security
HC05SC27	16K	240	☐☐	3K	☐☐	5	☐☐	☐☐	☐☐	☐☐	contact factory	Production	Security 3-6V operation
HC05SC28	12K	246	☐☐	8K	☐☐	5	☐☐	☐☐	☐☐	☐☐	contact factory	Contact Sales	Security 3-6V operation

- ❑ ?15 years ago, Motorola and Bull CP8 defined the chip necessary for a smartcard
- ❑ ?By 1980 the world's first secure single-chip micro MC6805SC01 was designed primarily to help combat rising fraud in French banking applications.
- ❑ ?SC01 has gone on to become one of the world's most successful micros with tens of millions sold to date.
- ❑ ?Motorola was then the first to incorporate low power HCMOS technology and EEPROM on smartcard chips.
- ❑ ?They have continued to expand their portfolio to meet market demands and remain dominant in world smartcard market

# HC05 MCU Development WorkStation

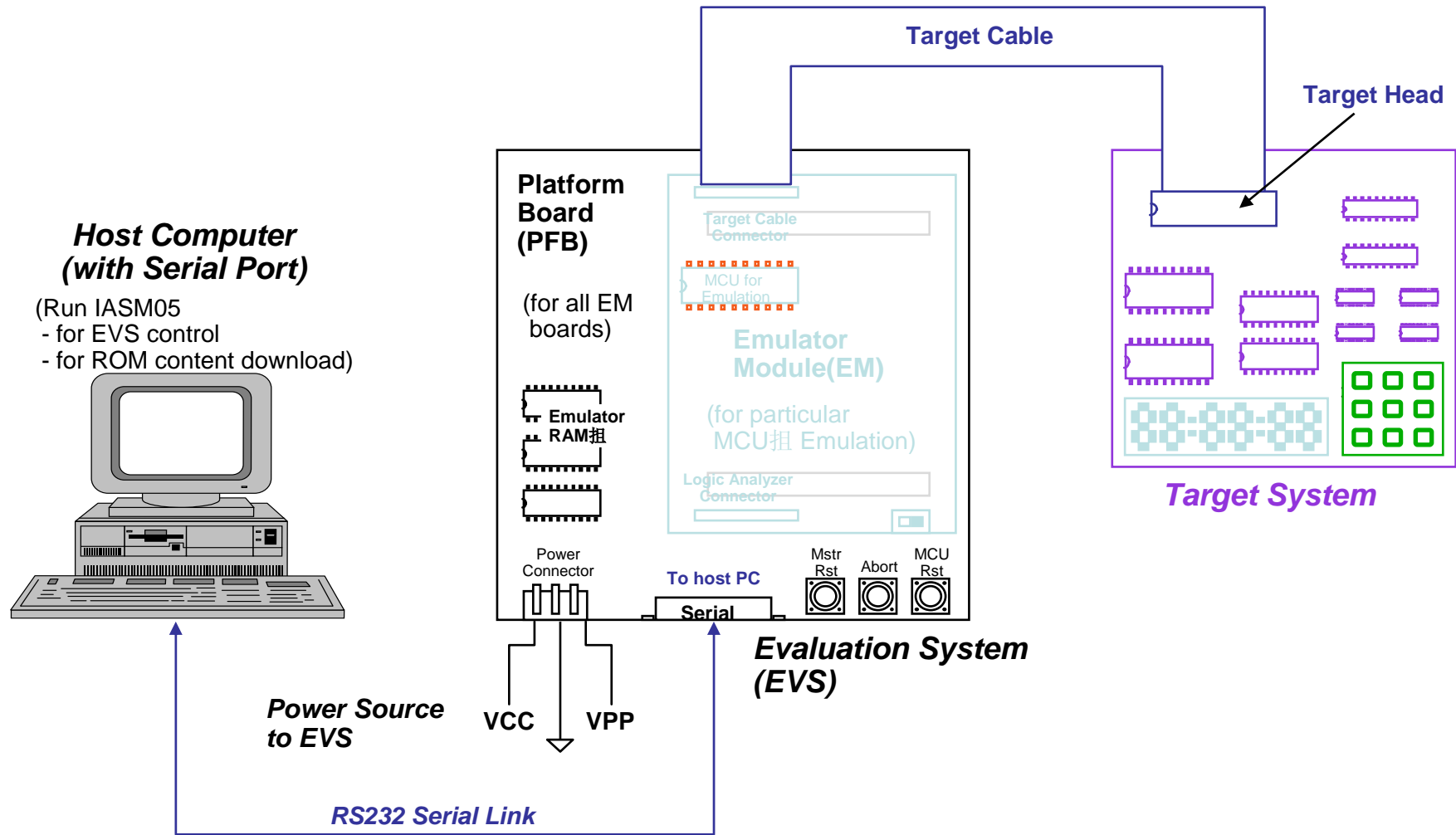

# HC08 Technology Improvement

## What and Why is HC08 CPU Core?

- Lower Cost - Down to 0.35um Technology
- Higher Performance - Up to 8MHz Bus Speed
- Lower Power - Low voltage operation
  - † 2.7 to 5.5 Volt Operation (standard)
  - † 2.0 Volt Operation (Optional)
- Higher Flexibility - Flash Technology
  - † In Circuit Programming (ICP)
  - † Multiple Field Firmware Upgrade (FFU)
- Better Noise Immunity and EMC Protection
  - † Oscillator with Electrical Fast Transient (EFT) Circuit
  - † More robust design & layout for better ESD and EMI

## HC08 Performance Improvement

# 68HC08 CPU Design

- Provide 68HC05 **Object Code Compatibility**, HC08 core is an architecturally Enhanced 68HC05 CPU core
- Increased Bus Speed to 8Mhz at 5V, 4MHz at 3V
- 5X Average Performance Increase over HC05s
- Extend Index & Stack Pointer to 16-bits, **C support**
- 78 New Instructions
- New Module-Based CSIC Design Methodology
- Fully Static Low Voltage / Low Power Design
- Use **FLASH** to replace EPROM, OTP, ROM

# 68HC08 vs. 68HC05 Performance

<u>Benchmark</u>	<u>8 MHz HC08</u>	<u>2 MHz HC05</u>
Interpolated Table Lookup	5.3	1.0
Character Search	6.2	1.0
Interrupt Driven I/O	5.6	1.0
Bit AND-OR	4.2	1.0
Vector Addition (Page 0)	6.3	1.0
Block Move	6.7	1.0
16 x 16 Multiply	5.6	1.0
Key Matrix Scan	4.6	1.0
Binary to BCD Conversion	<u>4.5</u>	<u>1.0</u>
Average	5.4	1.0

## In Circuit Programming Application

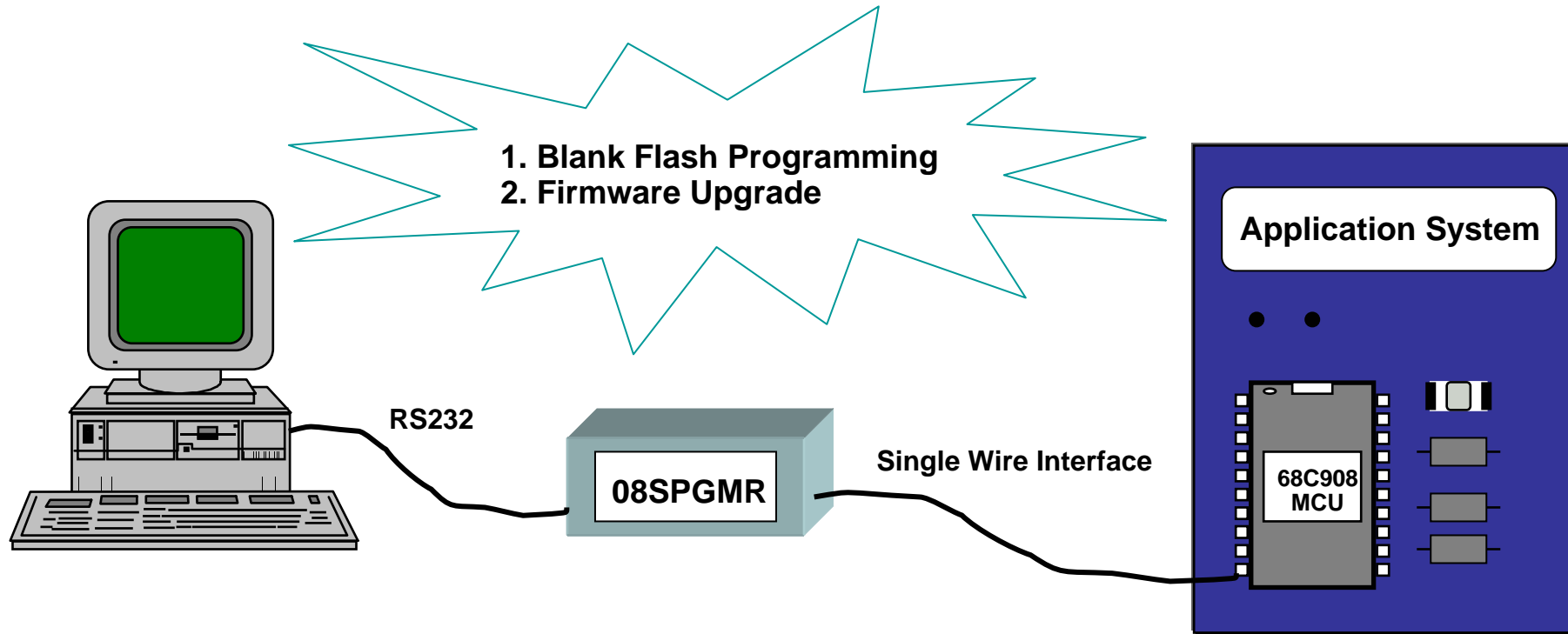

Only ONE single pin is required for programming

# Improved Oscillator Circuit

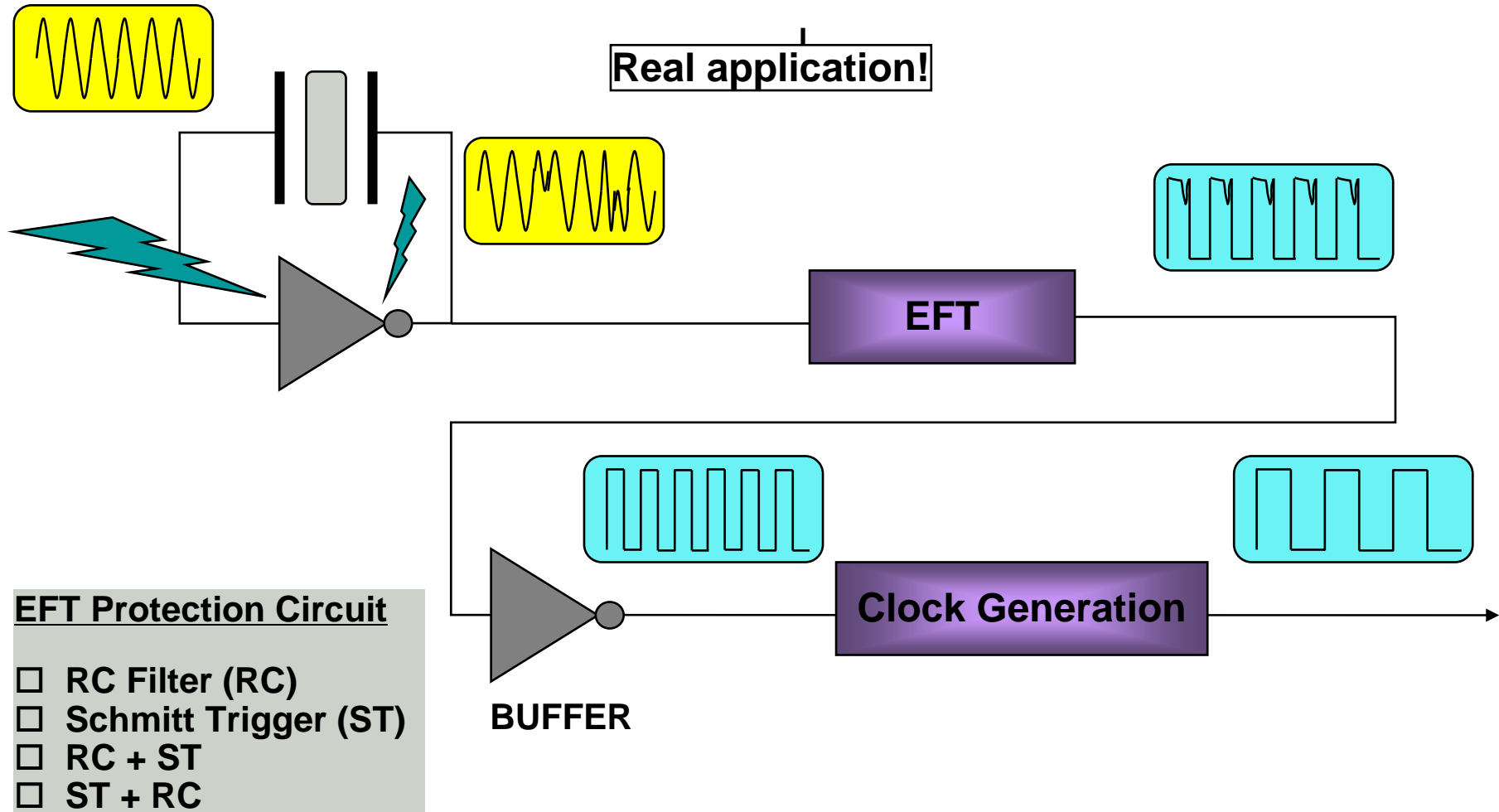

# HC08 Performance Improvement

## 68HC08 Modular Design Concept

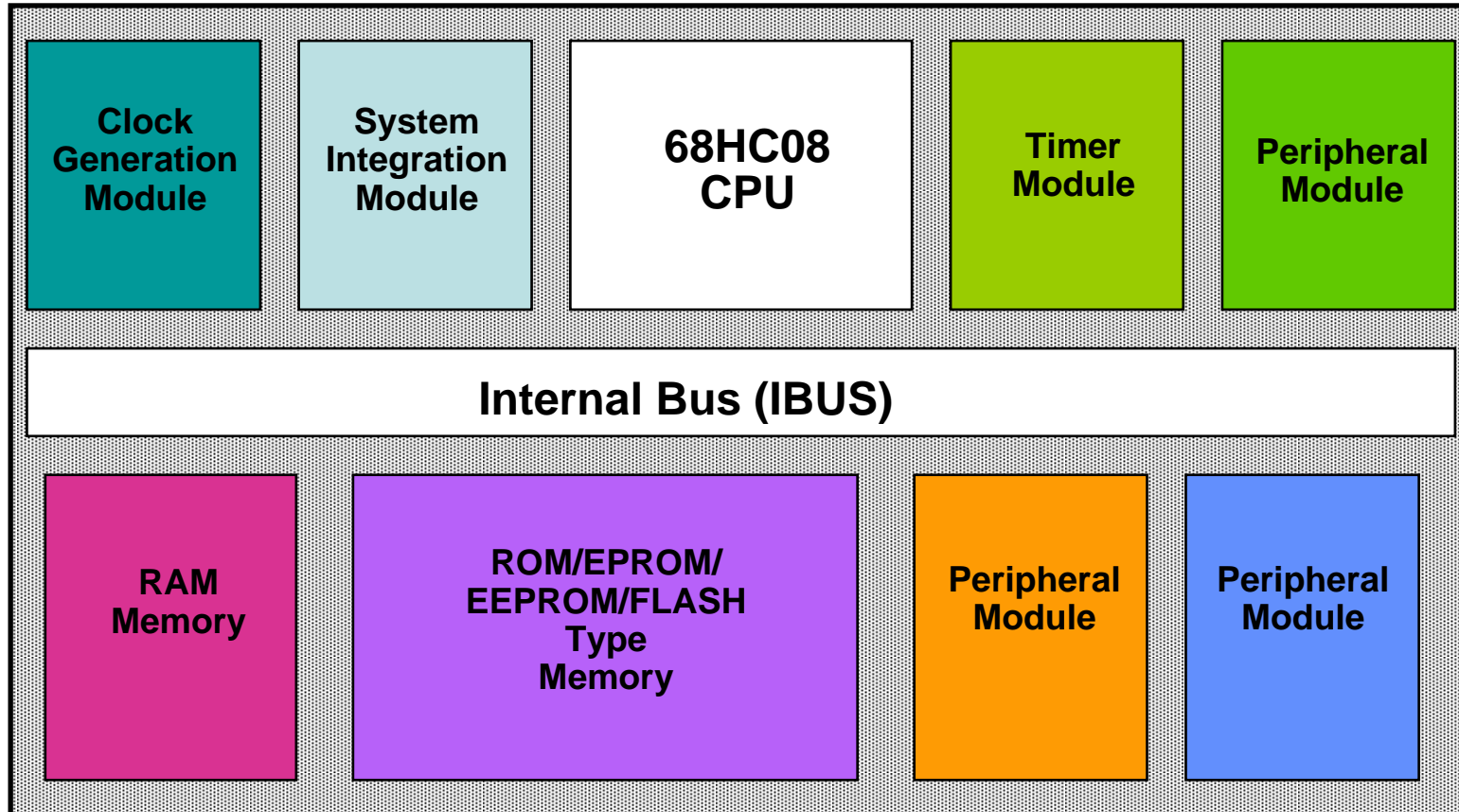

# Motorola FLASH Advantage

Why use Motorola's 2nd Generation 8-bit FLASH?

- ❖ In application re-programmability
- ❖ Reduced production programming costs
  - ❖ Up to 100 times faster than most embedded FLASH or OTP - 2msec for 64 bytes vs multiple ms/byte
- ❖ Use flash as data storage and save cost of EEPROM
  - ❖ 10K W/E cycles ([demo code available for GP32/JL3](#))
  - ❖ Over 10K W/E cycles by Paging Method
- ❖ Programs across full operating voltage range
- ❖ Flexible block protection and security

***0.35/0.5 micron FLASH 68HC08s shipping in volume at prices comparable or better than equivalent OTPs!***

# Family of Application Specific MCU's for USB Peripherals

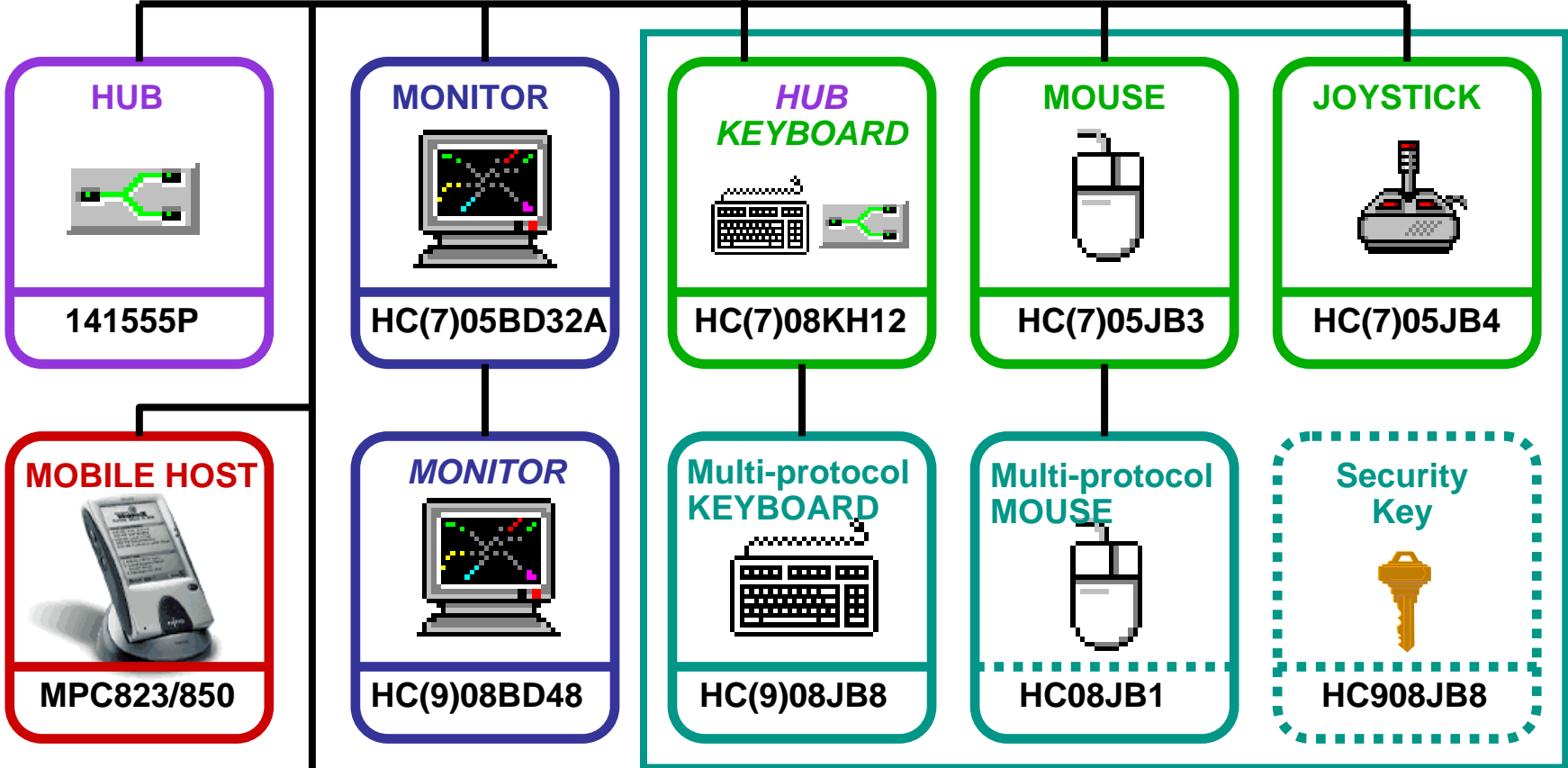

Security, 1.1 Full speed, 2.0 high speed

HID Peripherals

# Motion Control 8-bit MCU Portfolio

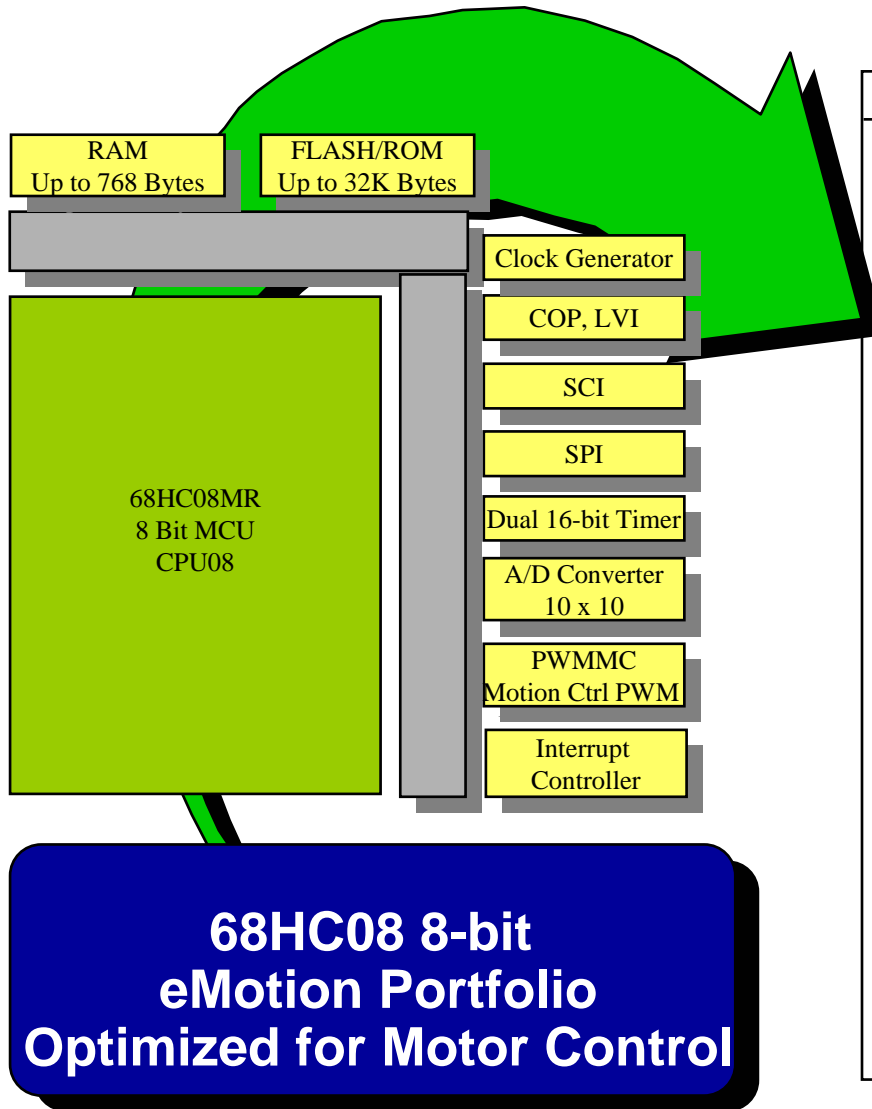

**68HC08 8-bit  
eMotion Portfolio  
Optimized for Motor Control**

	908MR32	908MR16	908MR8	08MR4
Target Market	Variable Speed 3-Phase Motion Control			
Operating Frequency	8MHz	8MHz	8MHz	8MHz
Core	CPU08	CPU08	CPU08	CPU08
Technology	0.50μ	0.50μ	0.50μ	0.5μ
Temp Range	-40 to 105	-40 to 105	-40 to 105	-40 to 105
I/O Voltage	5.0V	5.0V	5.0V	5.0V
Bus Width (bits)	8	8	8	8
Flash Memory (bytes)	32K	16K	8K	N/A
Read Only Memory	N/A	N/A	N/A	4K bytes
PLL	☐	☐	☐	☐
SCI	☐	☐	☐	☐
SPI	☐	☐	☐	☐
COP WatchDog Timer	☐	☐	☐	☐
16-bit Timers	6 Channel	6 Channel	4 Channel	4 Channel
GPIO	44	44	16	16
Low Voltage Inhibit	☐	☐	☐	☐
Ext Interrupt Controller	☐	☐	☐	☐
PWM	6 Channel	6 Channel	6 Channel	6 Channel
Single Wire interface	☐	☐	☐	☐
ADC	10 x 10-bit	10 x 10-bit	7 x 10-bit	7 x 10-bit
Sample Production	Now	Now	July'01	Feb'01
Development Tool	Now	Now	Apr,'01	Apr,'01
Package	64 QFP 56 SDIP	64 QFP 56 SDIP	32 QFP 28 DIP/SOIC	32 QFP 28 DIP/SOIC

# Electronic Motor Control Application Notes

<http://www.mot-sps.com/motor>

AN1590	High Voltage Medium Power Board for 3 Phase Motors
AN1857	3 Phase AC Induction Motor Control System Based on the 68HC908MR32
AN1858	Sensorless Brushless DC Motor using 68HC908MR32
AN1712	"Get Your Motor Running" with the 68HC708MP16
AN1728	Making Low-Distortion Wave Forms Using the 68HC708MP16
AN1792	Using the 68HC908MR24 in Place of the 68HC708MP16
AN1844	Using the 68HC908MR32 in Place of the 68HC908MR24
<b>Re-usable motion control design techniques may also be found in the following application notes:</b>	
AN1627	Low Cost High Efficiency Sensorless Drive for BLDC Motor Using the 68HC705MC4
AN1661	Low Cost Universal Motor Chopper Drive System Using the 68HC705MC4
AN1662	Low Cost Universal Motor Phase Angle Drive System Using the 68HC05JJ6/68HC705JJ7

**ACMC Pre-programmed solution (08MR4):**

**The pre-programmed AC Motor Controller will be available in  
This will be MMD's first pre-programmed Motor Control chip**

**MC68HC908QY4/QY2/QY1(16Pin)**

**MC68HC908QT4/QT2/QT1(8Pin)**

- Low Cost
- 1.5~4K Flash
- 128 Bytes RAM
- 4 Ch. 8Bits A/D (QY)
- Dimmable internal Oscillator (5%)
- 8Mhz internal Bus Clock
- 5V or 5V Power supply

# MC68HC908QYx and QTx

128 RAM	KBI
4 / 1.5K Flash / ROM	4-ch 8/10-Bit ADC(16 pin only)
Low Voltage Inhibit	2-ch 16-Bit Timer
Trimmable Internal RC Osc.	

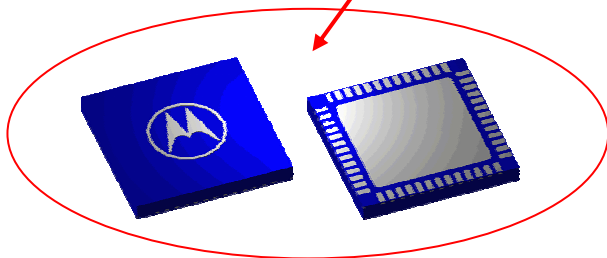

## Advantages

- Trimmable Internal RC Oscillator BUS : 3.2MHz +-25% (factory trimmed at 3.2MHz)
  - (+/-5% up to 125degC)
- Smallest MCU package – 4mm x 4mm QFN
- Lots of Free / 25USD demo kit
- Free 4k memory size C compiler
- Continuous family development
  - 2V version (MC on Mar, May 2003 Production)
  - 10 bit ADC
  - Mask ROM

MC68HLC908QT/QYx

## Applications

- Any low end feature light cost sensitive application
  - Charger
  - FAN
  - Small Home Appliance / Home Appliance
  - Auto Body Electronics

# MC68HC908QT/QY Family

## Low Voltage – MC68HLC908QT/QY

	Flash	ROM	RAM	Timer	I/O	ADC	Operating Voltage	Max Bus Frequency	Temp	Package	Status
<b>908QT4</b>	4k		128	2-ch 16-Bit IC, OC, PWM	6	4-ch 8-Bit	3 to 5	8MHz	C,M	8 SOIC 8 PDIP 8 QFN	MC
<b>908QT2</b>	1.5k		128	2-ch 16-Bit IC, OC, PWM	6	4-ch 8-Bit	3 to 5	8MHz	C,M	↓	MC
<b>908QT1</b>	1.5k		128	2-ch 16-Bit IC, OC, PWM	6	-	3 to 5	8MHz	C,M	↓	MC
<b>908QY4</b>	4k		128	2-ch 16-Bit IC, OC, PWM	14	4-ch 8-Bit	3 to 5	8MHz	C,M	16 SOIC 16 PDIP 16 SSOP	MC
<b>908QY2</b>	1.5k		128	2-ch 16-Bit IC, OC, PWM	14	4-ch 8-Bit	3 to 5	8MHz	C,M	↓	MC
<b>908QY1</b>	1.5k		128	2-ch 16-Bit IC, OC, PWM	14	-	3 to 5	8MHz	C,M	↓	MC

# MC68HC908KXx

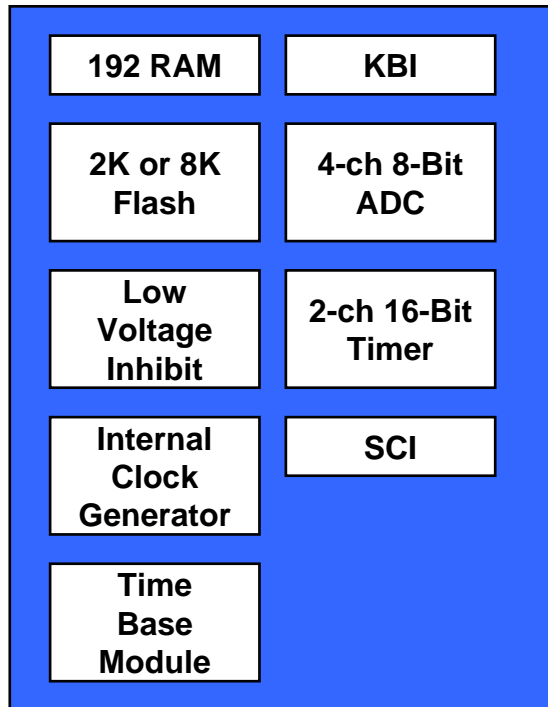

## Advantages

- Internal Clock Generator eliminates need for external clock source, improves accuracy across temperature and voltage and allows programming at a target frequency
- Smallest IC with SCI in the portfolio

## Applications

- Low pin count, feature rich applications

	Flash	ROM	RAM	Timer	I/O	Serial	ADC	Operating Voltage	Max Bus Frequency	Temp	Package	Status
<b>908KX8</b>	8k		192	2-ch 16-Bit IC,OC,PWM	13	SCI	4-ch 8-Bit	3 or 5	8 MHz	C, V, M	16 DIP 16 SOIC	MC
<b>908KX2</b>	2k		192	2-ch 16-Bit IC,OC,PWM	13	SCI	4-ch 8-Bit	3 or 5	8 MHz	C, V, M	16 DIP 16 SOIC	MC

# MC68HC(9)08JLx and JKx

128 / 256 RAM	JL8 - SCI
1.5K, 4K, 8K Flash / ROM	12-ch 8-Bit ADC
Low Voltage Inhibit	1-2 x 2-ch 16-Bit Timer
XTAL or RC oscill	6 pin LED Drive

## Advantages

Pin and feature compatible family from 20-32pin and 1.5K – 8K flash.

All 4k and 8k flash version has corresponding Mask ROM

Highest number of I/O in 32sdip package – 27 I/Os on 9JL8

Low voltage version – MC68HLC908JL3, JK3, JK1

Min 2V V<sub>dd</sub>, Flash – read only, ADC 0.5-2 LSB

## Applications

UPS, chargers

Aircond, refrigerator, W/M, heater, oven

# Low End HC08 JL and JK-family

	Flash	ROM	RAM	Timer	I/O	Serial	ADC	Operating Voltage	Max Bus Frequency	Temp	Package	Status
<b>908JL8</b>	8k		256	2-ch 16-Bit IC,OC,PWM	23 / 27	SCI	12-ch 8-Bit	3 to 5	8MHz	C, M	LQFP 32 SDIP32 SOIC 28 DIP 28	MC
<b>08JL8</b>		8k	256	2-ch 16-Bit IC,OC,PWM	23 / 27	SCI	12-ch 8-Bit	3 to 5	8MHz	C, M	LQFP 32 SDIP32 SOIC 28 DIP 28	Under Develop
<b>908JK8</b>	8k		256	2-ch 16-Bit IC,OC,PWM	15	SCI	10-ch 8-Bit	3 to 5	8MHz	C, M	20 SOIC DIP 20	MC
<b>08JK8</b>		8k	256	2-ch 16-Bit IC,OC,PWM	15	SCI	10-ch 8-Bit	3 to 5	8MHz	C, M	20 SOIC DIP 20	Under Develop
<b>908JL3</b>	4k		128	2-ch 16-Bit IC,OC,PWM	23	None	12-ch 8-Bit	3 to 5	8 MHz	C, M	DIP 28 SOIC 48 LQFP 32	MC
<b>08JL3</b>		4k	128	2-ch 16-Bit IC,OC,PWM	23	None	12-ch 8-Bit	3 to 5	8 MHz	C, M	DIP 28 SOIC 48 LQFP 32	MC
<b>908JK3</b>	4k		128	2-ch 16-Bit IC,OC,PWM	15	None	10-ch 8-Bit	3 to 5	8 MHz	C, M	DIP 20 20SOIC	MC
<b>908JK1</b>	1.5k		128	2-ch 16-Bit IC,OC,PWM	15	None	10-ch 8-Bit	3 to 5	8 MHz	C, M	DIP 20 SOIC 20	MC
<b>08JK3</b>		4k	128	2-ch 16-Bit IC,OC,PWM	15	None	12-ch 8-Bit	3 to 5	8 MHz	C, M	DIP 20 SOIC 20	MC

# MC68HC(9)08GP32 and GT8/16

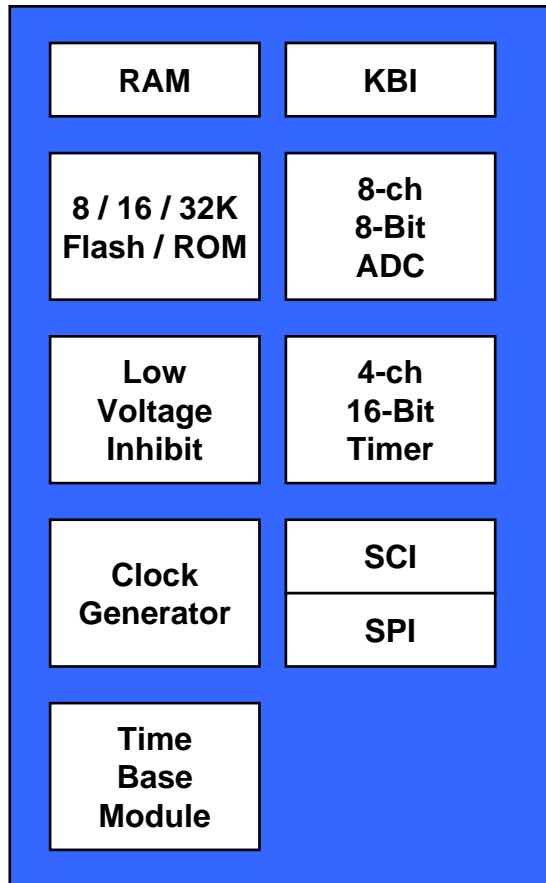

## Advantages

- Pin compatible family from 8K to 32K flash
- Time base module provides auto wake up from low power stop mode to maintain real-time clock or check external devices such as sensors.
- CGM and PLL provide high performance using low-cost low frequency reference crystals. Reduces noise while still providing high performance.

## Applications

- General Purpose
- Home Appliance, Set top box

# General Purpose HC08 G-family

	Flash	ROM	RAM	Timer	I/O	Serial	ADC	Operating Voltage	Max Bus Frequency	Temp	Package	Status
<b>908GP32</b>	32k		512	Dual 2-ch 16-Bit IC, OC, PWM	33	SCI, SPI	8-ch 8-Bit	3.0, 5.0	8MHz	C	40 DIP 44 QFP 42 SDIP	MC
<b>08GP32</b>		32k	512	Dual 2-ch 16-Bit IC, OC, PWM	33	SCI, SPI	8-ch 8-Bit	3.0, 5.0	8MHz	C	44 QFP 42 SDIP	MC
<b>908GT16</b>	16k		512	Dual 2-ch 16-Bit IC, OC, PWM	34 / 36	ESCI, SPI	8-ch 8-Bit	3.0, 5.0	8MHz	C	42 SDIP 44 QFP	MC
<b>908GT8</b>	8k		384	Dual 2-ch 16-Bit IC, OC, PWM	34 / 36	ESCI, SPI	8-ch 8-Bit	3.0, 5.0	8MHz	C	42 SDIP 44 QFP	MC
<b>908GR16</b>	16k		1K	Dual 16-Bit	21 / 37	ESCI, SPI	8-ch 10-Bit	3.0, 5.0	8MHz	C	32 QFP 48 QFP	MC in Mar03
<b>908GR8</b>	8k		384	Dual 16-Bit	17 / 23	ESCI, SPI	8-ch 8-Bit	3.0, 5.0	8MHz	C	28PDIP 42 SDIP	MC

# 68HC908GP32

Upward HC05 Object Code Compatible

512 Bytes RAM

32,292 Bytes Flash / ROM

Single-Wire Development Interface

Address-Match Hardware Breakpoints

Reset / Interrupt Priority Control

External Interrupt

Watchdog

Low-Voltage Inhibit

32kHz Clock Generator Module/PLL

Time Base Module

DIP 40, SDIP 42, QFP 44

ROM MC Qualified

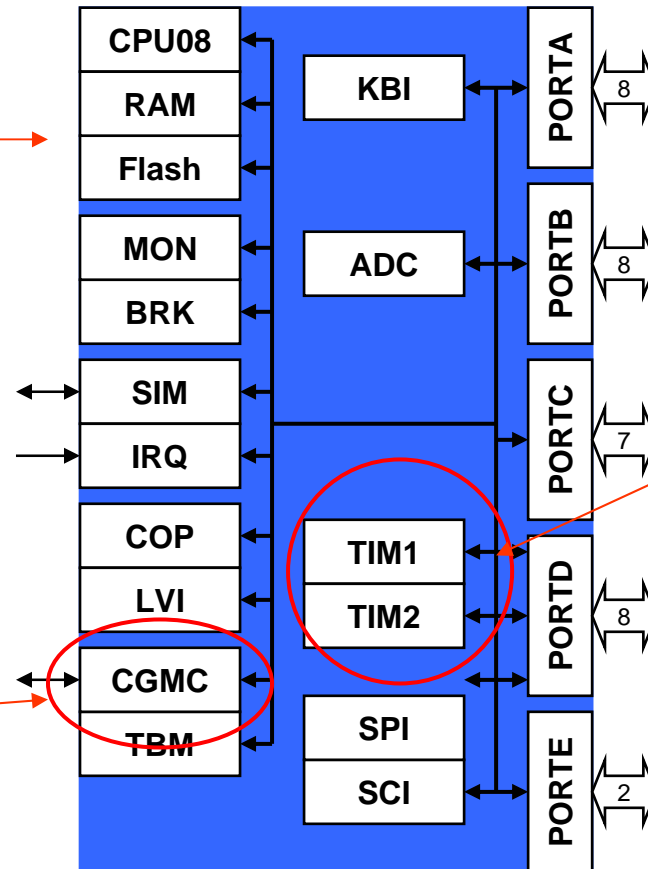

8 Keyboard Interrupts

8 Channel / 8-Bit  
Analog-to-Digital Converter

33 Bi-directional I/O  
All Ports Pins Rated for  
• 10mA Sink  
• 10mA Source

Dual 2 Channel 16-Bit Timer:  
• Input Capture  
• Output Compare  
• Pulse Width Modulation

Synchronous Serial  
Peripheral Interface

Asynchronous Serial  
Communications Interface

- Move Down to 2.4V Vdd Operation
- GP32 IDK from Tsinghua
- AN2105 - Power On, Clock Selection and Noise Reduction Technique

# MC68HC(9)08SR12

## Advantages

512 RAM	KBI
12K Flash/ROM	14-ch 10-Bit ADC
Low Voltage Inhibit	4-ch 16-Bit Timer 3xPWM
Clock Generator Module + Osc	SCI
	I <sup>2</sup> C/SMBus
Time Base Module	Temp
	Current

- Master I<sup>2</sup>C Bus which is SMBus compatible.
- Advanced analogue functions which provide cost savings. Better than 1° C resolution, amplifier gain up to 16X reduces need for op amps. Generates an interrupt when current is detected.

## Applications

- Power management using SMBus ver 1.1
- Any application with need to read environmental details
- Any application that requires high number of ADC channels



	Flash	ROM	RAM	Timer	I/O	Serial	ADC	Operating Voltage	Max Bus Frequency	Temp	Package	Status
908SR12	12k		512	Dual 2-ch 16-Bit IC, OC, PWM	31	I <sup>2</sup> C SCI	14-ch 10-Bit	3 or 5	8 MHz	C, M	48 QFP 42 SDIP	MC
08SR12		12k	512	Dual 2-ch 16-Bit IC, OC, PWM	31	I <sup>2</sup> C SCI	14-ch 10-Bit	3 or 5	8 MHz	C, M	48 QFP 42 SDIP	MC

# MC68HC908AB32 and AB16A

## Advantages

512/1K RAM	KBI
32K Flash 16K ROM	8-ch 8-Bit ADC
Low Voltage Inhibit	8-ch 16-Bit Timer
Clock Generator Module	SCI
	SPI
Periodic Interrupt Timer	512 EEPROM

- Integrated byte erasable EEPROM
- Big RAM size, up to 1K byte
- Lots of I/O pins - 51

## Applications

- Automotive
- High end Home Appliance
- Industrial Control

	Flash	ROM	RAM	Timer	I/O	Serial	ADC	Operating Voltage	Max Bus Frequency	Temp	Package	Status
<b>908AB32</b>	32k		1K	Dual 4-ch 16-Bit IC, OC, PWM	51	SCI SPI	8-ch 8-Bit	5	8MHz	C, V, M	64 QFP	MC
<b>08AB16A</b>		16k	512	Dual 4-ch 16-Bit IC, OC, PWM	51	SCI SPI	8-ch 8-Bit	5	8MHz	C, M	64 QFP	MC

# MC68HC908AP16/32/64 Family

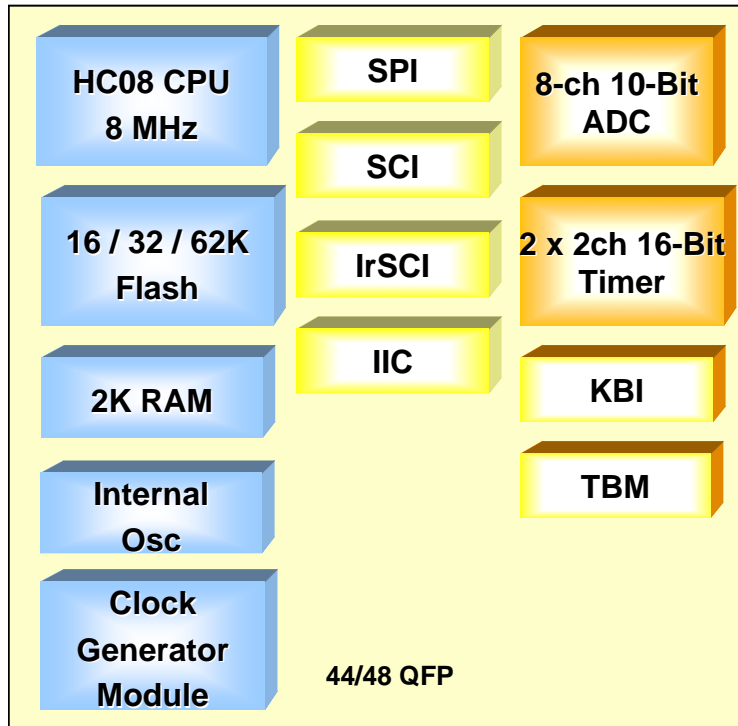

## Advantages

- Most feature rich general purpose 44pin MCU
- Rich suite of Communications Peripherals 1 x SCI, 1 x IrSCI, SPI and IIC
- Lots of RAM 1-2k byte
- Flexible Oscillator / XTAL options
  - Separate Internal RC for COP Watchdog
- Firmware embedded in Monitor ROM for EEPROM emulation in Flash

## Applications

- Electronic power meters, Sensors, Wireless communications, Home appliances, Security systems

	Flash	ROM	RAM	EEPROM	Timer	I/O	Serial	ADC	Operating Voltage	Frequency	Temperature	Package	Status
<b>908AP64</b>	62K	-	2K	-	2 x 2ch 16-Bit 1 x 8 bit	30 / 32	SCI, IrSCI, SPI, IIC	8ch 10bit ADC	3.0V or 5.0V	8MHz	C	42SDIP,44 QFP,48LQF P	MC in May 03
<b>908AP32</b>	32K	-	2K	-	2 x 2ch 16-Bit 1 x 8 bit	30 / 32	SCI, IrSCI, SPI, IIC	8ch 10bit ADC	3.0V or 5.0V	8MHz	C	42SDIP,44 QFP,48LQF P	MC in May 03
<b>908AP16</b>	16K	-	1K	-	2 x 2ch 16-Bit 1 x 8 bit	30 / 32	SCI, IrSCI, SPI, IIC	8ch 10bit ADC	3.0V or 5.0V	8MHz	C	42SDIP,44 QFP,48LQF P	MC in May 03

# MC68HC(9)08LJ12

## Advantages

512 RAM	KBI
12K ROM/Flash	6-ch 10-Bit ADC
Low Voltage Inhibit	2 x 2ch 16-Bit Timer
Clock Generator Module	SCI
	SPI
LCD Driver	Real Time Clock Module

- Real Time Clock function enables calendar function and software chronograph counter. Selectable periodic interrupt request for seconds minutes, hours days, 2Hz, 4Hz and 100Hz.
- LCD Driver has maximum of 26 frontplane and static, three and four backplane drivers.
- Normal Vdd 3-5.5V, Low voltage MC68HLC908LJ12 Vdd 2.4V

## Applications

- Home Appliance
- Power Meter
- Instrument (Blood Pressure Meter)

	Flash	ROM	RAM	Timer	I/O	Serial	ADC	Operating Voltage	Max Bus Frequency	Temp	Package	Status
<b>908LJ12</b>	12k		512	2 x 2ch 16-Bit	32	SCI SPI	6-ch 10-Bit	2.4 or 5	8MHz	C	64 QFP 52 LQFP	MC

# MC68HC(9)08LJ24

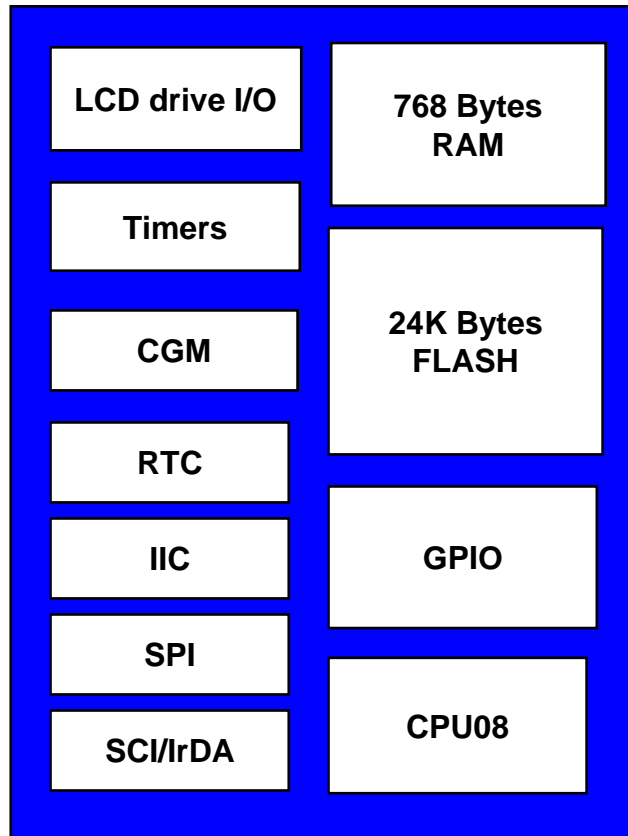

## Advantages

- Low Power RTC, under 5uA
- Serial communications interface module (SCI) with IR modulator/demodulator
- 22~30 direct LED source pins 15mA
- LCD Driver with
  - 64-QFP : 4 back plane and 26 front plane
  - 80-QFP : 4 back plane and 32 front plane
- Pin compatible with 64pin 9LJ12
- Normal Vdd 3-5.5V, Low voltage MC68HLC908LJ24 Vdd 2.4V

## Applications

- Power Meter, Instrumentation, FRS, DSC

	Flash	RAM	Timer	I/O	LCD	Serial	ADC	Operating voltage	Max Bus Frequency	Temp	Package	Status
908LJ24	24k	768	Dual 2-ch 16-Bit	40	4 x 26	SCI, SPI, IIC	6-ch 10-Bit	2.4 -5.5	8MHz	C	64 QFP	Sample
				48	4 x 32						80 QFP	

# MC68HC908MRxx

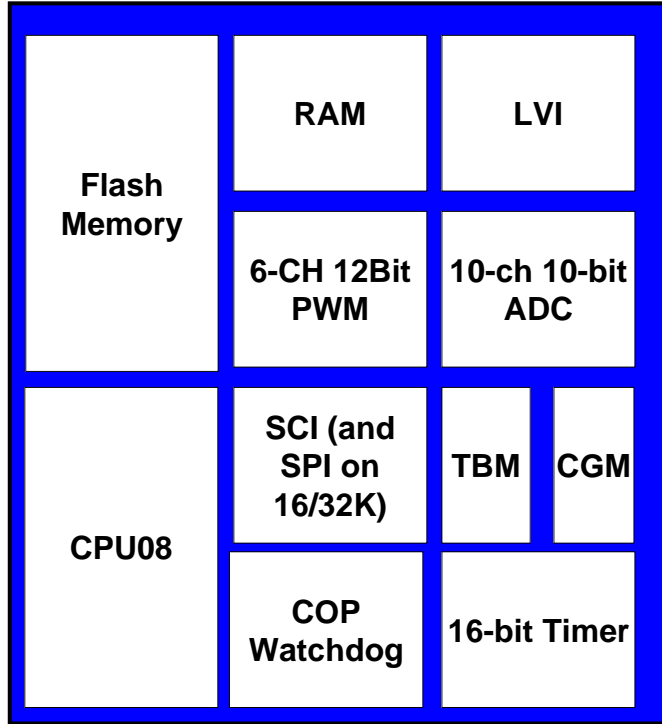

## Advantages

- 10-bit ADC and PWM designed specifically for 3 phase AC or BLDC Motor Control
- Industrial only 28/32 pin 3Phase control MCU – 9MR8
- Center or edge aligned PWM ideal for motor control

## Applications

- 3-phase, variable speed motor control applications - HA
- Industrial Motor Control

	Flash	ROM	RAM	Timer	I/O	Serial	ADC	Operating Voltage	Max Bus Frequency	Temp	Package	Status
<b>908MR32</b>	32k	-	768	4-ch + 2-ch 16-Bit	44	SPI SCI	10-ch 10-Bit	5	8MHz	C,V	64 QFP 56 SDIP	MC
<b>908MR16</b>	16k	-	768	4-ch + 2-ch 16-Bit	44	SPI SCI	10-ch 10-Bit	5	8MHz	C,V	64 QFP 56 SDIP	MC
<b>908MR8</b>	8k	-	256	Dual 2-Ch 16-Bit	14	SCI	7-ch 10-Bit	5	8MHz	C,V	32 LQFP 28 DIP / SOIC	MC

# MC68HC908EY16

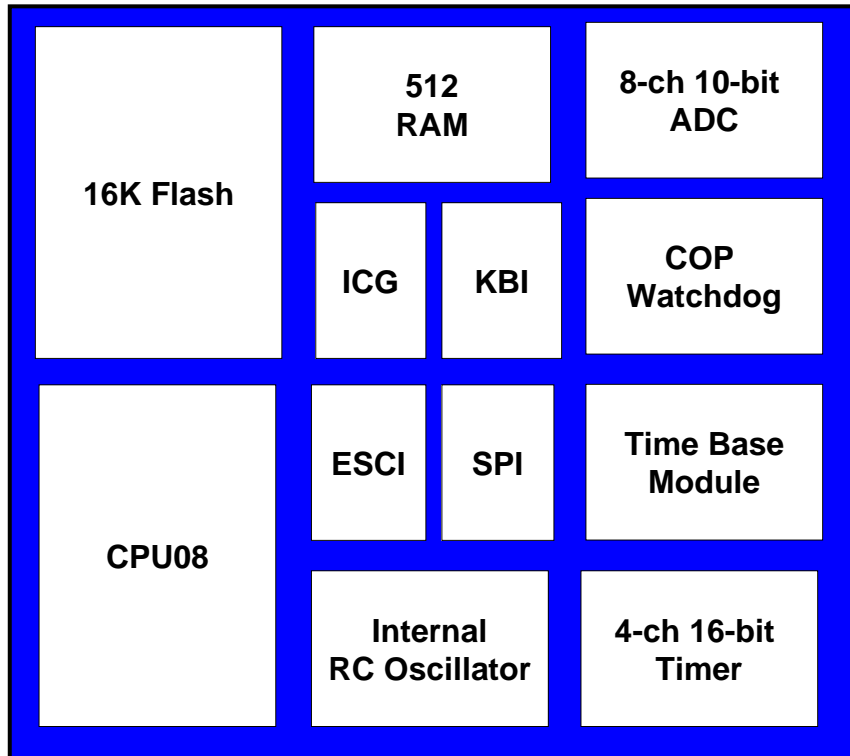

## Advantages

- On chip RC oscillator no external circuitry required
  - Trimmable to 5%
- Enhanced SCI with 13 Bit Break detect
- 10 Bit ADC
- Cyclic Wake Up feature via time base module

## Applications

- Ideal for *LIN* automotive applications
- 32 QFP with small footprint for space sensitive application

	Flash	ROM	RAM	Timer	I/O	Serial	ADC	Operating Voltage	Max Bus Frequency	Temp	Package	Status
<b>908EY16</b>	16k	-	512	4-Ch 16-Bit	24	ESCI SPI	8-ch 10-Bit	3 or 5V	8MHz	M	32 QFP	MC

# HC908GZ8/16 (Low Cost CAN)

MSCAN08		2x 2-ch 16 bit	1K RAM
4x10 bit ADC	8/16kB Flash	Monitor ROM	CPU08 Core
ESCI	SPI	CGM	

## Advantages

- Low cost CAN MCU to replace 05X family
- Clock Generation Module provides up to 8.4MHz bus clock from either PLL driven by 1-8MHz crystal or standard crystal/ceramic resonator with /4
- 2 x 16 bit free running timers 1 used as RTI generator

## Applications

- Low end low cost Automotive and Industrial with CAN bus

	Flash	ROM	RAM	Timer	I/O	Serial	ADC	Operating Voltage	Max Bus Frequency	Temp	Package	Status
<b>908GZ16</b>	16k	-	1K	Dual 2-ch 16-Bit	21 / 37	ESCI SPI	4-Ch 10-Bit	3 or 5V	8MHz	M	32/48 QFP	MC on Mar03
<b>908GZ8</b>	8k	-	1K	Dual 2-ch 16-Bit	21 / 37	ESCI SPI	4-Ch 10-Bit	3 or 5V	8MHz	M	32/48 QFP	MC on Mar03

# MC68HC(9)08AZxxA

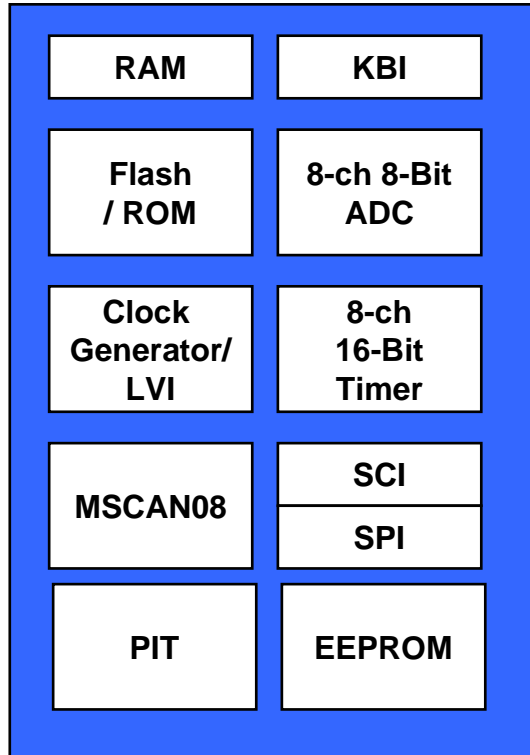

## Advantages

- Most popular Automotive CAN bus MCU in the industrial
- Integrated byte erasable EEPROM
- PIT provide programmable interrupt function.

## Applications

- Automotive and Industrial
- Any application that benefits from on board EEPROM
  - (9)08AZ32A : 512 byte
  - (9)08AZ60A : 1K byte



	Flash	ROM	RAM	Timer	I/O	Serial	ADC	Operating Voltage	Max Bus Frequency	Temp	Package	Status
<b>908AZ32A</b>	32K		512	4-ch + 2-ch 16-Bit	50	CAN/SCI/ SPI	15-ch 8-Bit	5	8	C/V/M	64 QFP	Samples
<b>08AZ32A</b>		32K	512	6-ch + 2-ch 16-Bit	50	CAN/SCI/ SPI	15-ch 8-Bit	5	8	C/V/M	64 QFP	MC
<b>908AZ60A</b>	60K		1K	6-ch + 2-ch 16-Bit	50	CAN/SCI/ SPI	15-ch 8-Bit	5	8	C/V/M	64 QFP	MC
<b>08AZ60</b>		60K	1K	6-ch + 2-ch 16-Bit	48	CAN/SCI/ SPI	15-ch 8-Bit	5	8	C/V/M	64 QFP	MC

# 68HC908JB8, 08JB8, 08JT8, 08JB1

Upward HC05 Object Code Compatible

256 Bytes RAM

8K Bytes Flash / ROM

Single-Wire Development Interface

Address-Match Hardware Breakpoints

Reset / Interrupt Priority Control

External Interrupt

Watchdog

Low-Voltage Inhibit

Clock Oscillator

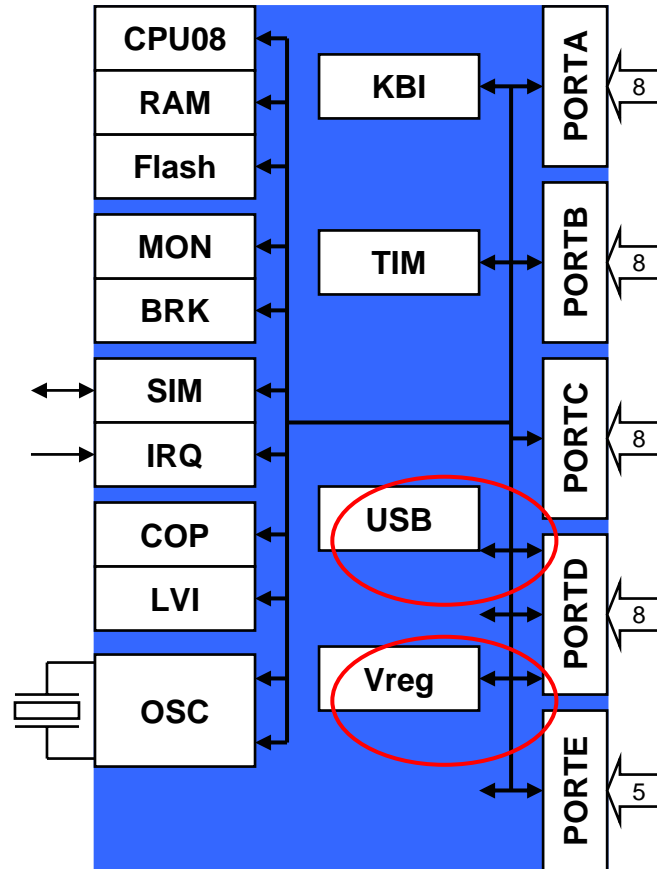

8 Keyboard Interrupts

2 Channel 16-Bit Timer

- Input Capture
- Output Compare
- Pulse Width Modulation

Up to 37 Bi-directional I/O

28pin - 21 I/O

20pin - 13 I/O

- 10 mA on 8 pins
- 25 mA on 2 pins

USB

- 1.5 Mbps

3.3 V Regulator

QFP 44, DIP 20, SOIC 28

3 ROMs - 08JB8/JT8 (8K) MC'ed

08JB1 (5.5K) MC'ed

	ROM	RAM	Package
JB8	8K	256	20/28/44
JB1	5.5K	128	20pin

- 5V VDD, 3MHz Bus
- RESET, IRQ 0-5V operation
- I/Os are 0-3.3V operation
- 08JT8 1.8-3V Operation, NO USB, NO Vreg, NO LVI

# New USB RF Receiver MCU - HC908JB16

- HC08 CPU Core
  - external 12MHz XTAL and 6 MHz *CPU bus clock*
- 16384 bytes Flash Memory(*with security*) and 384 bytes RAM
- Fully Compliant Low Speed(1.5Mbps) USB 1.1 Interface
  - Control Endpoint 0 with separate 8-byte Tx/Rx FIFOs
  - Interrupt Endpoint 1 with 8-byte Tx FIFO and Endpoint 2 with separate 8-byte Tx/Rx FIFOs
  - suspend/resume operation and device remote wakeup
  - Vref(3.3V  $\pm$  10%) for USB line pullup
  - USB port pins mux with 10mA High Current pins (with prog. pullup R) to switch between PS/2 & USB Interfaces [*Multiprotocol*]
- Two 16-bit 2-channel Timer Interface Modules(TIM) with rising and falling edges Input Capture/Output Compares
- Serial communication interface module (SCI)
- Up to 21 Bi-directional I/O Pins
  - 12 with programmable pullups at PTA0-7, PTC0-1, and PTE3-4
  - 8-bit keyboard interrupts at PTA0-7
  - LED Direct Drive Pin : 4 10mA pins at PTD2-5 and PTE3-4, and 2 25mA pins at PTD0-1.
- Dual clock generator modules (PLL) for 27MHz wireless HID application
- Packages : 32-pin LQFP, 28-pin SOIC

# CRT/LCD Monitor MCU

## HC908LD60/64/120

### FEATURES :

- 6MHz Bus, 24MHz external crystal
- 60K Flash
- 1K Ram (2K Ram - 9LD64)
- Sync Processor which contains H/V, Composite, or digital SOG SYNC signal frequency counters, H/V polarity detection, (auto) polarity controlled, selectable H/V Sync outputs, and the CLAMP pulse output, fast Horizontal frequency measurement, low vertical frequency detect
- 8-Ch 8-bits PWM
- 8-bit ADC
- 39 General purpose I/O
- 2-Ch 16-bit Timer
- DDC12AB module
- Additional Multi-Master IIC
- USB HUB and OSD, 908LD64 Only

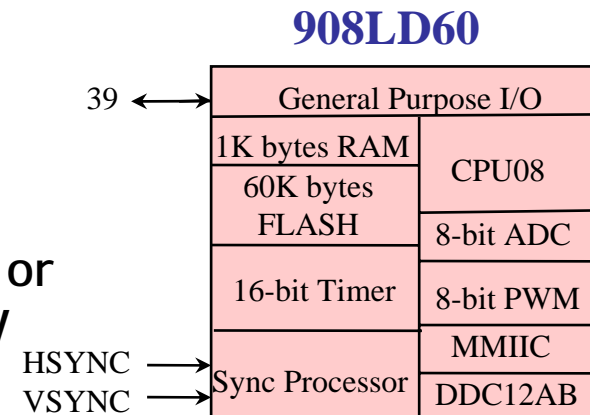

# MC9S08A Family , G Family

	FLASH	RAM	Timer	I/O I/O	Serial	A/D	Vdd	Max. Bus clock	pack age	comment
S08AW60	60K	2K	6Ch.+2Ch. 16b IC,OC PWM	Up to 50	2SCI 1SPI IIC	16Ch. 10b	5V 3V	20M Hz	44 48 64	Low V. Inhibit Warm. Highly accurate internal oscillator
S08AW48	48K									
S08AW32	32K									
S08GB60	60K	4K	8Ch. 16b IC,OC or PWM	56	2SCI  1SPI	8Ch.  10b	1.8V  to  3.6V	20M Hz	64	BDM
S08GB32	32K	2K		36						
S08GT60	60K	4K								
S08GT32	32K	2K								
S08GT16	16K	2K								

# MC9S08R Family

	FLASH	RAM	Timer	I/O	Serial	A/D	Vdd	Max. Bus clock	pack age	comment
S08RC8	8K	1K	2Ch.	Up	No		1.8V	8MHz	32	Analog Comparator Low Voltage Warning
S08RC16	16K								44	
S08RC32	32K	2K	16b	To			To		44	Low Voltage Warning
S08RC60	60K								28	
S08RD8	8K	1K	IC	39			3.6V		28	Low Voltage Warning
S08RD16	16K								32	
S08RD32	32K	2K	OC						32	
S08RD60	60K								44	
S08RE8	8K	1K	PWM						44	Analog Comparator
S08RE16	16K								32	
S08RE32	32K	2K							44	
S08RE60	60K								32	
S08RG32	32K	1K			SCI					
S08RG60	60K	2K			SPI					

# Reference Book in Chinese



1995



1998

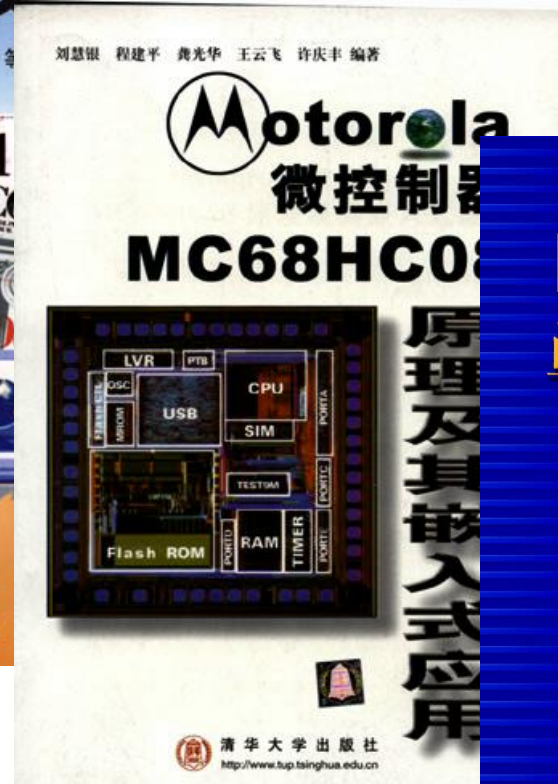

2000

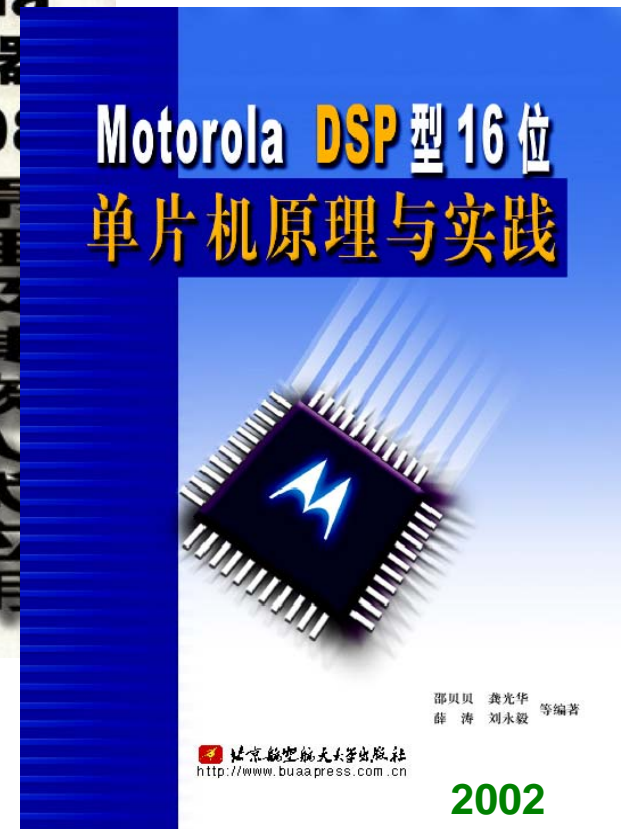

2002

# 9S12D Family

HCS12 CPU	Dual 10bit, 8ch.
Up to 512K FLASH	Enhanced Capture Timer 16bit, 8ch.
	PWM 8bit 8ch./16bit 4ch
	2 x SCI
	3 x SPI
12K RAM	IIC
4K EEPROM	BDLC J1850 Interface
16 Key Wakeup IRQ Ports	Up to 5 Advanced MSCAN12
	Vreg 5V to 2,5V

- Advantages

- Up to 5 x enhanced msCAN 12
- J1850
- Fully compatible code and pin compatible family from 32KBytes to 512KBytes of Flash

- Applications

- Automotive, Industrial
- Any application requiring large I/O, memory (Flash RAM and EEPROM) and sophisticated communication.

	RAM	Flash	EEPROM	Speed	SCI	SPI	IIC	ADC	Vcc	I/O	CAN	Other	Timer	PWM	Package
9S12DP512	14K	512K	4K	25/33	2	3	1	16 Ch 10 Bit	5V	59 - 91	5	J1850	8Ch 16Bit (ECT)	8Ch 8Bit	112LQFP
9S12Dx256	12K	256K	4K	25MHz	2	3	1	16 Ch 10 Bit	5V	59 - 91	2->5	J1850	8Ch 16Bit (ECT)	8Ch 8Bit	112LQFP, 80QFP
9S12Dx128	8K	128K	2K	25MHz	2	2	1	16 Ch 10 Bit	5V	59 - 91	2->3	J1850	8Ch 16Bit (ECT)	8Ch 8Bit	112LQFP, 80QFP
9S12D64	4K	64K	1K	25MHz	2	1	1	16 Ch 10 Bit	5V	59 - 91	1	J1850	8Ch 16Bit (ECT)	8Ch 8Bit	112LQFP, 80QFP
9S12D32	2K	32K	1K	25MHz	2	1	-	8 Ch 10 Bit	5V	59	1	-	8Ch 16Bit (ECT)	7Ch 8Bit	80QFP

# HCS912A Family - General purpose

HCS12 CPU	Dual 10bit, 8ch.
Up to 512K FLASH	Enhanced Capture Timer 16bit, 8ch.
	PWM 8bit 8ch./16bit 4ch
	Up to 2 x SCI
12K RAM	Up to 3 x SPI
4K EEPROM	IIC
16 Key Wakeup IRQ Ports	Vreg 3V to 2.5V

## Advantages

- Feature Rich Peripheral Set, flash base
- 3V - 5V Supply voltage
  - 3V to be introduced after 5V
  - 2.5V Internal core
- 2 x SCI, 3 x SPI, IIC

## Applications

- Any application requiring high performance, I/O, memory at low cost and low voltage
- Industrial (Elevator, Petrol Pump), Line Card, Card Reader, Security

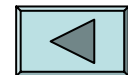

	RAM	Flash	EEPROM	Speed	SCI	SPI	IIC	ADC	Vcc	I/O	CAN	Other	Timer	PWM	Package
9S12A512	14K	512K	4K	25/33	2	3	1	16 Ch 10 Bit	3 or 5	59 - 91	-	-	8Ch 16Bit (ECT)	8Ch 8Bit	112LQFP
9S12A256	12K	256K	4K	25MHz	2	3	1	16 Ch 10 Bit	3 or 5	59 - 91	-	-	8Ch 16Bit (ECT)	8Ch 8Bit	112LQFP, 80QFP
9S12A128	8K	128K	2K	25MHz	2	2	1	16 Ch 10 Bit	3 or 5	59 - 91	-	-	8Ch 16Bit (ECT)	8Ch 8Bit	112LQFP, 80QFP
9S12A64	4K	64K	1K	25MHz	2	1	1	16 Ch 10 Bit	3 or 5	59 - 91	-	-	8Ch 16Bit (ECT)	8Ch 8Bit	112LQFP, 80QFP
9S12A32	2K	32K	1K	25MHz	2	1	-	8 Ch 10 Bit	3 or 5	59	-	-	8Ch 16Bit (ECT)	7Ch 8Bit	80QFP

# HCS912B Family

HCS12 CPU	10bit, 8ch ADC
Up to 256K FLASH	Enhanced Capture Timer 16bit, 8ch
	PWM 8bit 8ch./16bit 4ch
	2 x SCI
	SPI
RAM	MSCAN12
EEPROM	Vreg 5V to 2,5V
16 Key Wakeup IRQ Ports	

## Advantages

- Feature Rich Peripheral Set
- Enhanced msCAN 12

## Applications

- Any application requiring high performance but fewer features and EEPROM than HCS12D-family offers



	RAM	Flash	EEPROM	Speed	SCI	SPI	IIC	ADC	Vcc	I/O	CAN	Other	Timer	PWM	Package
9S12B256	8K	256K	2K	16Mhz	2	1	-	8 Ch 10 Bit	5V	59 - 91	1	-	8Ch 16Bit (TIM)	8Ch 8Bit	112LQFP, 80QFP
9S12B128	4K	128K	1K	16Mhz	2	1	-	8 Ch 10 Bit	5V	59 - 91	1	-	8Ch 16Bit (TIM)	8Ch 8Bit	112LQFP, 80QFP
9S12B64	2K	64K	1K	16Mhz	2	1	-	8 Ch 10 Bit	5V	59	1	-	8Ch 16Bit (TIM)	7Ch 8Bit	80QFP

# HCS912C32 - Goldfish

The MC9S12C family is a **low-cost**, high performance version of the MC9S12 family of 16-bit microcontroller units (MCUs), utilising the enhanced MC9S12 core.

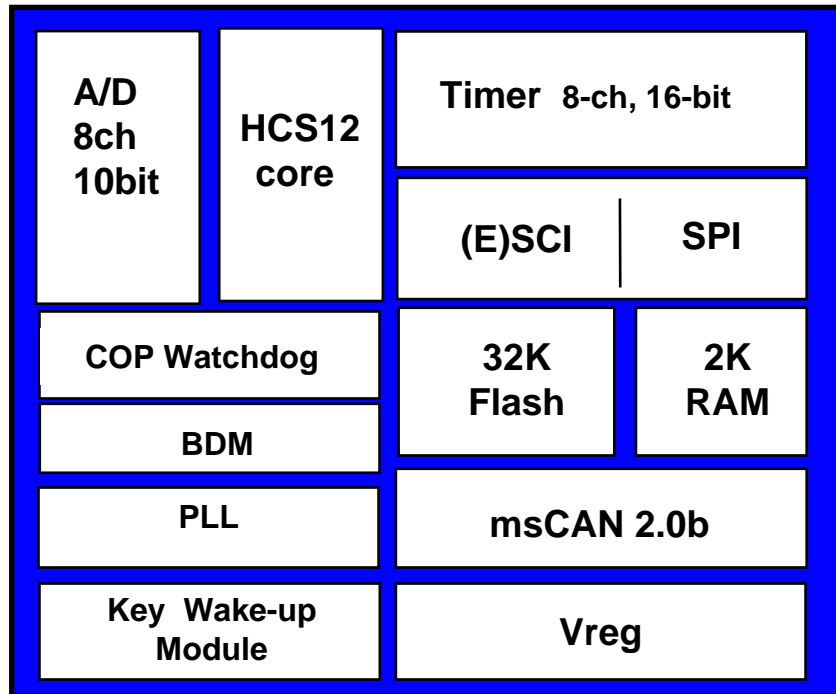

- Advantages
- 3V - 5V operation
- 16-Bit performance at 8-Bit price
- Entry level HCS12 Device
- Applications
- Application which require high performance but smaller memory and package than other HCS12
- Road in to HCS12 family for high end HC08 parts.



# HCS912H Family

HCS12 CPU	ADC 10-bit, 8-ch
256K FLASH	PWM 8bit 6ch/16bit 2ch
	2 x Advanced MsCAN12
12K RAM	2 x SCI
4K EEPROM	1 x SPI
Vreg 5V to 2,5V	IIC
4 x 32 LCD display driver	Timer 16-bit 8-ch

- Advantages
- 4 x 32 LCD display driver
- 24 high current drivers for PWM motor control which supports sin and cos drive, dithering and output slew limitation
- ADC with external conversion trigger capability
- Applications
- Any application that required some LCD drive I/O



	RAM	Flash	EEPROM	Speed	SCI	SPI	IIC	ADC	Vcc	I/O	CAN	Other	Timer	PWM	Package
9S12H256	12K	256K	4K	16Mhz	2 or 1	1	1	16-Ch 10-Bit	5V	93	2	32x4 LCD	8Ch 16Bit (TIM)	2 or 6 ch	112LQFP, 144LQFP
9S12H128	6K	128K	2K	16Mhz	1	1	-	8-Ch 10-Bit	5V	61	2	32x4 LCD	8Ch 16Bit (TIM)	2 or 6 ch	112LQFP

# HCS912L Family - Display Family

- So many industrial applications have a user interface & instrumentation cluster, with parallels to automotive cluster needs.
- The partitioning option highlighted here has drivers on board to attack low multiplexed LCD displays which have less characters.
- External addressing maintained to access look-up tables.

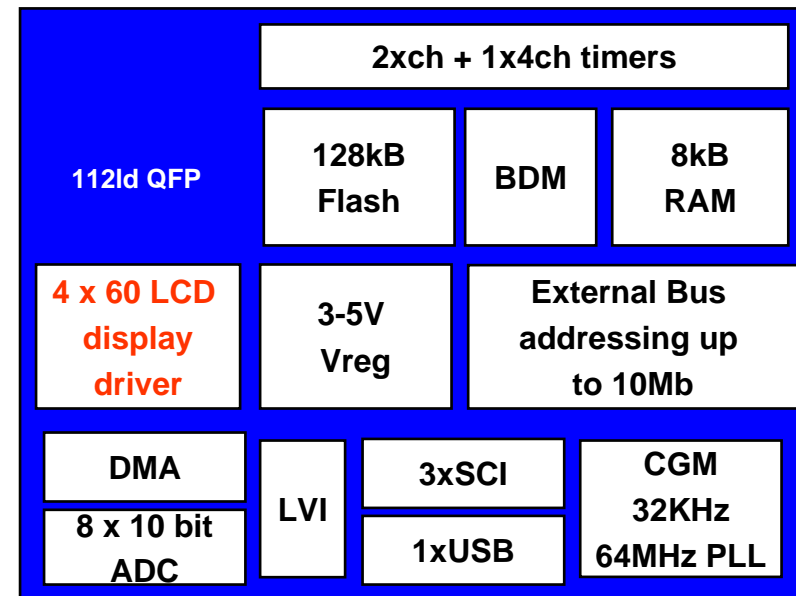
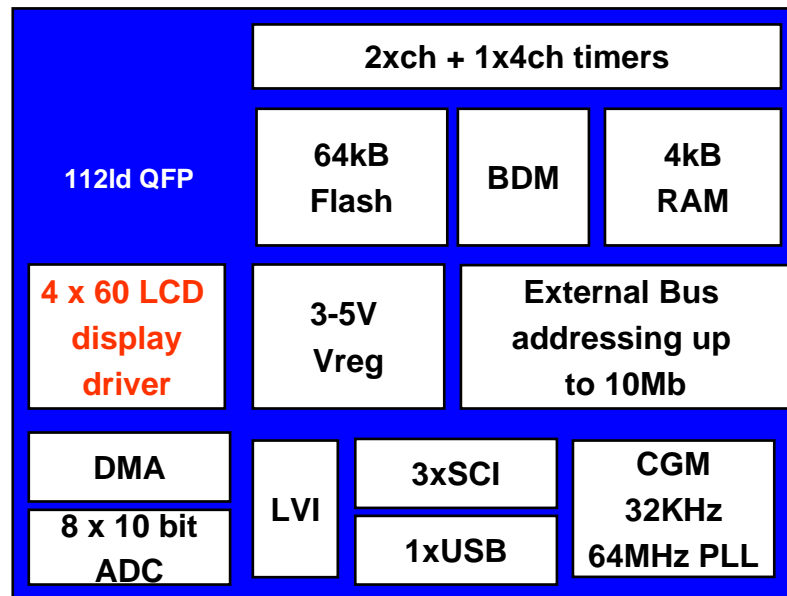

# 9S12E128

- S12 16-Bit CPU Core
- 8K Bytes RAM
- 128K Bytes FLASH EEPROM
- Single-Wire Background Debug
- Address-Match Hardware Breakpoints
- Reset / Interrupt Priority Control
- External Interrupt
- Watchdog
- Low-Voltage Inhibit
- Clock Generation and Reset Module

3.3V to 5V operating voltage  
25MHz bus  
80-QFP

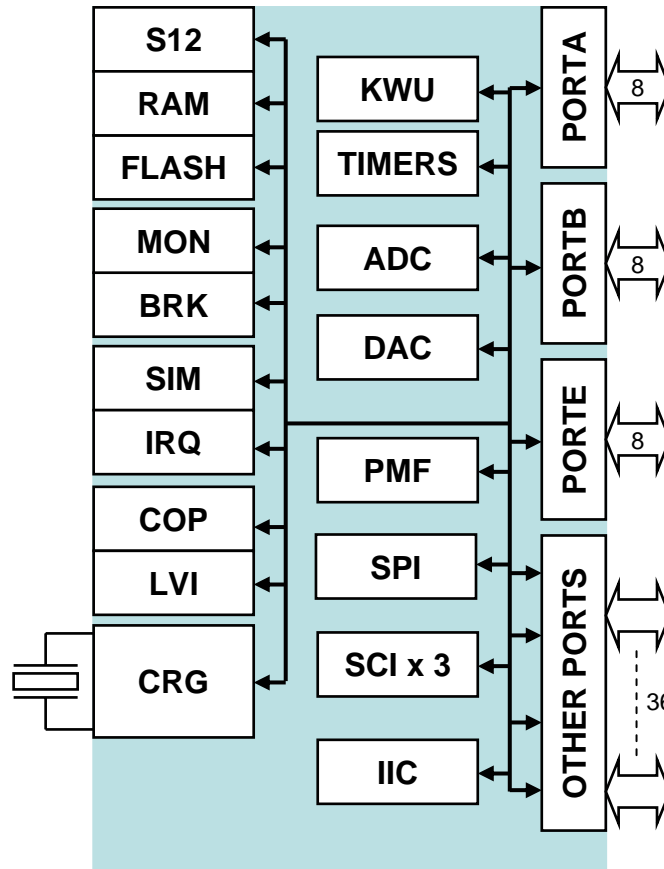

60 Bi-directional I/O

20 Keypad Wakeup Inputs

3 x 4-Channel Timers

- 8-bit programmable with IC and OC channels
- 16-bit pulse accumulators

16-Channel 10-Bit ADC

2-Channel 10-Bit DAC

6-Channel Pulse Modulator with Fault Protection

Serial Peripheral Interface

3 x Serial Communications Interface

Inter-IC Bus

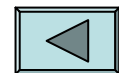

# 9S12NE64/32

S12 16-Bit CPU Core

8K Bytes RAM

64 Bytes FLASH EEPROM

Single-Wire Background Debug

Address-Match Hardware Breakpoints

Reset / Interrupt Priority Control

External Interrupt

Watchdog

Low-Voltage Inhibit

Clock Generation and Reset Module

3.3V to 5V operating voltage

25MHz bus

80-QFP

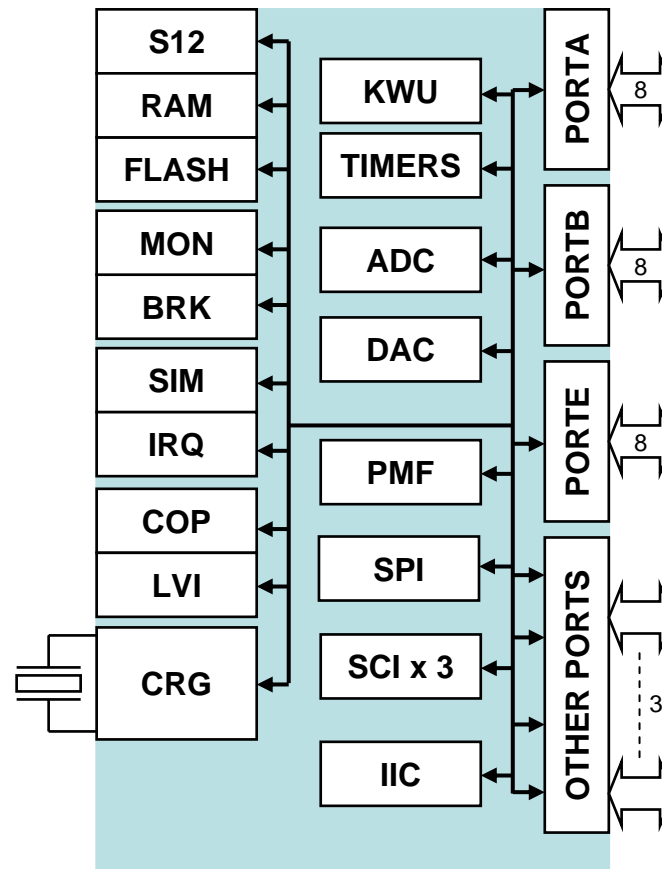

60 Bi-directional I/O

20 Keypad Wakeup Inputs

3 x 4-Channel Timers

- 8-bit programmable with IC and OC channels
- 16-bit pulse accumulators

16-Channel 10-Bit ADC

2-Channel 10-Bit DAC

6-Channel Pulse Modulator with Fault Protection

Serial Peripheral Interface  
3 x Serial Communications Interface

**Ethernet interface**

Inter-IC Bus

# 9S12UF32

S12 16-Bit CPU Core

1K Bytes RAM

32K Bytes FLASH EEPROM

Single-Wire Background Debug

Address-Match Hardware Breakpoints

Reset / Interrupt Priority Control

External Interrupt

Watchdog

Low-Voltage Inhibit

Clock Generation and Reset Module

Universal Serial Bus 2.0

3.3V to 5V operating voltage

25MHz bus

100-QFP

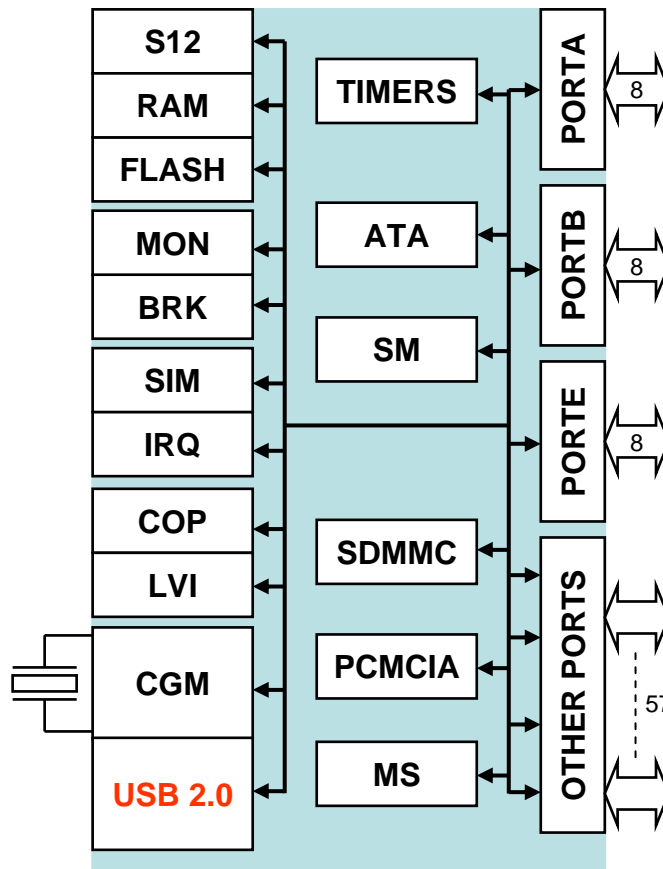

81 Bi-directional I/O

Timer

- 16-bit main counter
- 8-bit programmable with IC and OC channels
- 16-bit pulse accumulators

ATA Interface

Smart Media Interface

MMC System v2.1 and  
SD Memory Card v1.0  
Interface, Compact Flash

MemoryStick/MagicGate  
Interface

## 32b MCU: ColdFire

- **MCF5206,5207,5213,5214,5216,5232,5233,5234,5235,5249,5270,5271,5272,5274,5275,5280,5281,5282,52233,52235**
- **MCF5307**
- **MCF5407,5470,5471,5472,5473,5474,5475,5480,5481,5482,5483,5485**

## Other 32b MCU

- M68K:
  - 68301, 68302, 68331, 68336...
  - 68332, 68376, 68375...
- PowerPC
  - PPC821, 823, 860...
  - PPC555, 561/2/3/4/5...
- ARM
  - MX1, MXII...
- M.Core
  - 2104, 2107... C.Core

# MCU Web Site



<http://www.mot.com/>

<http://www.Freescale.com/>

→ **Products and Service**

→ **Semiconductor**

→ **Products**

→ **Microcontroller**

8bits  
16bits  
32bits

- **Selection Guides, new/Q**
- **FAQ knowledge database**
- **Application Note, example downloads**
- **Data Sheet**
- **Reference manual**
- **Development software downloads**
- **Searchable third party database**

# **MCU Selector Guide (SG1006/D)**

**See Selection Guide 2004. 3**

**Do Select Best MCU for Your Application!**